

# ORION TELECOM NETWORKS INC.

---



## VCL-STM-1

VCL100MC-1 (Upto 63 E1)

## System Guide

16810, Avenue of Fountains, Suite # 108,  
Fountain Hills, AZ 85268, USA

**Phone:** +1 (480) 816 8672

**Fax:** +1 (480) 816 0115

**E-mail:** [sales@oriontelecom.com](mailto:sales@oriontelecom.com)

**Web Site:** <http://www.oriontelecom.com>

---

# INDEX

<b>S. No.</b>	<b>Particulars</b>	<b>Page. No.</b>
01.	Introduction	03
02.	Key Features	03
03.	System Hardware	04
04.	Network Element Software	06
05.	Network Management System	07
06.	Redundancy and Protection	07
07.	Ethernet Support on VCL100MC-1	08
08.	VCL100MC-1 Applications	08
09.	VCL100MC-1 Differentiators	12
10.	Technical Specifications	13

## INTRODUCTION

The VCL100MC-1 STM-1 is a compact, modular, and cost effective STM-1 SDH multiplexer equipment designed to manage bandwidth and provide E1 or fractional E1, voice and data access service over STM Networks. It is customized for the traffic demands, in the access network, typical of residential or business customers. The product supports end-to-end provisioning and management of services across all the segments of the optical network. It combines innovative optical networking software with the intelligence of SONET/SDH to deliver a flexible, cost-effective network solution.

VCL100MC-1 STM-1 is a compact 3U height Multi-Card Chassis System that provides flexibility to the customers in terms of expansion to support additional client interfaces by adding new modules in the field.

The system has two STM-1 optical/electrical interfaces in the aggregate side and allows for upto 3 tributary add-on cards. The following tributaries are available as add-on cards for the chassis:

- 28 E1/DS3 tributaries (software configurable as E1 or DS1)
- 1 E3/DS3 tributaries (software configurable as E3 or DS3)
- 8 port 10/100Base-T Ethernet (IEEE 802.3)
- 2xSTM-1o
- 2xSTM-1e

Additionally it provides a single 10/100Base-T Ethernet port, which can be mapped to one VC-12 bandwidth towards the aggregate side. This feature does not use any tributary slot and hence can supplement E1/DS1/E3/DS3 customers requiring a single Ethernet interface. This Ethernet interface on the base card is optional.

The STM-1 / STM-4 can be managed through an integrated NMS that manages all Orion equipment, providing customers with end-to-end provisioning from a single platform for multiple service types - from E1/DS1s, E3/DS3s, STM-1e, STM-1o and 10/100Mbps Ethernet services.

## Key Features

- Next generation access SDH multiplexers to provide multi-service solutions at the edge.
- Support for both TDM and data traffic services.
- Flexible set of configurations to meet customer's different service requirements.
- Brings the power of Intelligent Optical Networking from core to access.
- VCL100MC-1 STM-1 Multiplexer with:
  - Add/Drop, Terminal Multiplexer, Crossconnect and Regenerator configurations
  - E1/DS1, E3/DS3, STM-1e and 10/100 Mbps Ethernet tributaries
  - Built-in cross-connect capabilities at VC-12 and VC-3 granularity
  - Support for AU-3 and AU-4 mapping
  - Rate adaptive Ethernet services for easy control of bandwidth with 2Mbps granularity.

- Supports MSP and SNCP protection.
- "Point-and-click provisioning" of E1/DS1, E3/DS3, STM-1 and 10/100 Ethernet Interfaces for ease of management.
- Optional hardware redundancy for power supply.

## VCL100MC-1 System Hardware

### Chassis

The VCL100MC-1 is a 19" wide, 5.25" high 3 tributary-slot chassis, in a half-depth rack allowing back-to-back arrangement for VCL100MC-1s. This chassis can be installed in both 19" and 23" rack with suitable adapters.

Figure 1: Line sketch of the VCL100MC-1 Chassis

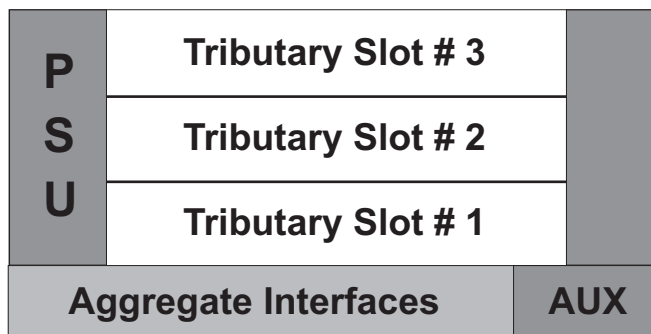
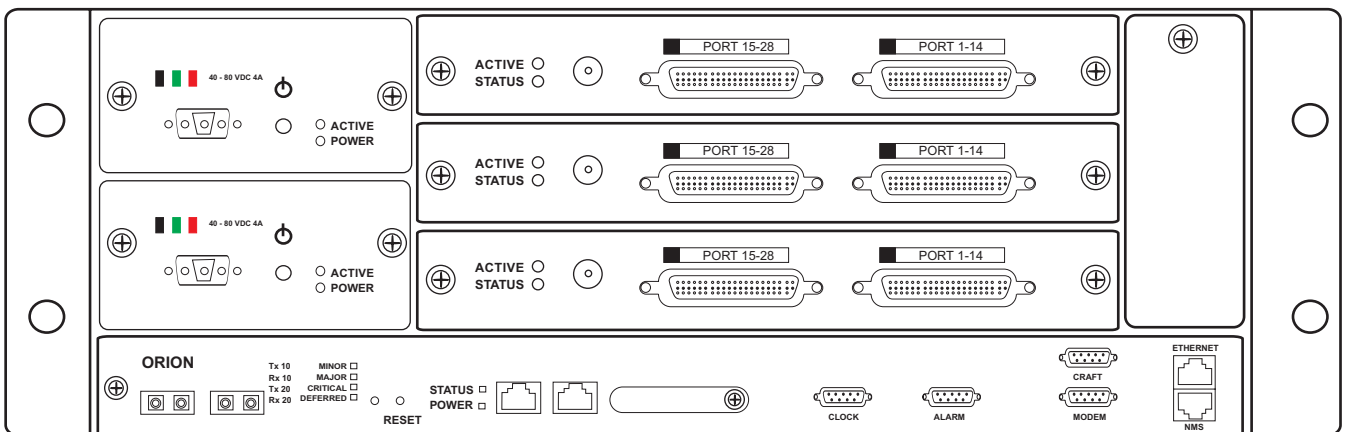

Figure 2: Faceplate layout



## Hardware components

### Base Chassis

The base chassis houses the following

**STM-1 interfaces:** 1 or 2 STM-1 o/e interfaces depending on Terminal multiplexer or Add-Drop Multiplexer configuration on the base card. The optics on these cards can be any of ITU-T G.957 S1.1, S1.2, L1.1, L1.2 depending upon link engineering data.

**Cross Connect Fabric :** A cross-connect fabric for 4x4 STM-1 with granularity of VC-12 (i.e 252x252) and VC-3 (i.e. 12x12) is built into the base chassis.

**Management interfaces:** This is provided through the 10/100 Mbps NMS (Ethernet) port or an RS232C craft port.

**Timing Interfaces:** External 2Mbps or 2.048 MHz timing signal inputs are provided for synchronizing the equipment. Further, reference 2Mbps reference output is provided.

**Engineering Order-wire:** This is provided through the analog 2-wire interface. The EOW bytes are software selectable to E1 or E2.

**Potential free contacts:** These provide dry contacts for extending the alarms. Five such potential free outputs are provided that are tied to alarms for Critical, Major, Minor, Order Wire and Power. Two potential free inputs are provided for environmental alarms like "Power or Air-conditioning failure", "equipment room door open" etc.

**Auxiliary Ethernet interface:** A single Ethernet interface is available to carry Ethernet data traffic over SDH. This is mapped to a single VC-12 on the aggregate side. This interface is optional.

### Power supply and Management Interfaces:

#### 28xE1/DS3 Tributary Card

Up to three 28 E1/DS1 tributary cards are supported in a single VCL100MC-1 chassis, the maximum in a single chassis being 63 E1 (maximum number for E1s) or 84 DS1 (maximum number for DS1) interfaces.

#### 1xE3/DS3 Tributary Card

Up to three 1xE3/DS3 tributary cards are supported in a VCL100MC-1 chassis. E3 traffic is carried in an AU4 mode.

#### 1/2xSTM-1optical / electrical

MC-1 can support one 1-port or 2-port STM-1 optical or electrical card in tributary slot#1. The optics on these card can be any of ITU-T G.957 S1.1, S1.2, L1.1 or L1.2 depending upon link engineering. All STM-1 interfaces need to be configured in the same mapping mode viz., AU3 or AU4, as the case maybe. STM-1e are software configurable.

#### 8-Port 10/100 Mbps Ethernet Tributary Card (ETC)

The 8-port Ethernet Tributary Card maps 10/100 Mbps Ethernet data on to VC-12's with a rate adaptation granularity of 2 Mbps. Each port's bandwidth is configurable in increments of 2Mbps, based on per port user demand. The aggregate bandwidth from each ETC card is at most STM-1 line rate (63 VC-12 worth of traffic). It also supports auto-negotiation and auto-sensing with full rate 10/100 Mbps Ethernet service. Ingress Ethernet traffic is shaped using flow control as per the standard IEEE 802.3x by using PAUSE control frames. This card is compliant to ITU-T X.86 and supports Virtual Concatenation.

## Power Supply Unit

Power to all the cards in the chassis is distributed from this unit accessible from the rear. This is a hot-insertible, hot stand-by current sharing power supply, running off a -36V to -60V DC supply. This would supply power to all the cards. This can be configured to be redundant.

**In some cases, VCL100MC-1 may be shipped with a fan tray unit.**

### Population Rules on VCL100MC-1

If the MC-1 is shipped with a fan tray unit,

1. The ETC Card is to be populated on tributary slot No.1
2. 28/21/16 E1 cards and E3 cards have to be located in tributary slot 2 and 3 respectively

*Note: The above rule is valid even if MC-1 is shipped with the fan tray unit but without an ETC*

If the MC-1 is shipped without a fan tray unit,

1. The ETC Card is to be populated on tributary slot No.3
2. 28/21/16 E1 cards and E3 cards have to be located in tributary slot 1 and 2 respectively

*Note: The above rule is valid even if MC-1 is shipped without an ETC*

## Synchronization

VCL100MC-1 can derive its clock from a variety of sources. VCL100MC-1 could be line-timed, externally timed or could derive its clock from its own internal Stratum-3 source. In a line-timed mode, it derives its clock from any one of the E1 tributaries or STM-1 signals. In an externally timed mode, an external 2048 KHz or 2 Mbps signal could be used as the clock source. If none of these sources are available, VCL100MC-1 goes into a holdover mode when it uses the stored timing data to control the output frequency for a short duration (of around 24 hrs). Beyond this it uses its own internal oscillator in a free-running mode.

VCL100MC-1 also supports Synchronization Status Messaging (SSM) as per ITU-T standards. This is a messaging technique, which enables a SDH equipment to determine the derivation of timing source. It uses overhead bytes contained within the SDH overhead (S1) for transmitting these messages. Thus when a failure occurs, elements communicate timing reconfiguration information across the network.

A 2.048 M BITS clock output is available from the system, which can be set to either a 2.048 MHz clock or a framed E1 data at 2.048 Mbps.

## VCL100MC-1 Network Element Software (NES)

The VCL100MC-1 node is managed through the embedded (Network Element Software). The main capabilities of NES are listed below:

- Switch over to redundant power supply in the event of any hardware fault.
- Auto Recovery after Input Power Failure in a redundant system
- Node-wise Operations & Maintenance
- User programmable severity levels for Alarms
- Node-wise Alarming & Remote Login.
- Performance monitoring as per the standard specifications (G.826).
- In-service monitoring of E1 tributaries.

A standard Network Element Software (NES) starter package enables all of the above.

User can access and control all of the above-mentioned features using a standard Hyper Text Transfer Protocol (HTTP) based web browser. The Ethernet interface on the base chassis is to be used as the physical data connection for this purpose. The NES also allows users to control remote nodes using the web browser interface. For this purpose Orion uses SDH DCC bytes for carrying the management information to the remote node.

To provide network wide management and control of VCL100MC-1 nodes through industry standard Network Management Systems, users can enable the Simple Network Management Protocol interface software module (NES-SNMP). This module provides open interfaces which can be also be used by Network Management System (NMS) which is described later in this document.

The (NES) point-and-click provisioning tool (PNCP) is a set of software modules that enables customers to provision end-end circuits in a network that comprises all Orion family of SDH products. Users can enable this feature using the node-resident software module NES-NODE-PNCP, and the server-resident software module NES-HOST-PNCP.

## Network Management System

The STM-1 / STM-4 provides support for centralized network management through Network Management System (NMS).

### Operations Interfaces

- 10/100 Mbps half-duplex LAN interface for NMS data connection to VCL100MC-1 node (RJ45 connector)
- RS232C Craft interface for local Command Line Interface data connection
- 2 wire analog telephone interface for Engineering Order Wire (E1 or E2 bytes access) with omnibus calling

## Redundancy and Protection

### Redundancy

- Optional redundant power supply card, operating as hot-standby and non-traffic affecting
- Hot insertion of tributary cards supported, with automatic synchronization of timing, data and provisioning information between redundant cards.
- Software redundancy for terminating and restarting critical processes with no service disruption.

### Protection mechanisms

- 1+1 Line Protection Switching (MSP as per G.783)
- VC-12 and VC-3 Path Protection Switching (LO/HO SNC as per G.841 8)

## Ethernet Support on VCL100MC-1

This section details the support for transport of Ethernet on SDH as offered on VCL100MC-1 and discusses some of its salient features.

Some of the salient features of the Ethernet transport support on VCL100MC-1 are:

- **Physical Interfaces** - The Ethernet tributary card (ETC) supports 10/100 BaseT physical interfaces. The interfaces support auto-sensing and auto-negotiation to detect flow control and line rate capabilities.
- **Bandwidth granularity** - VCL100MC-1 provides the flexibility to provide granularities from say 2 Mbps all the way to maximum limit of the physical interface, for instance 10 Mbps or 100 Mbps. The exact user demand is software provisionable in increments of 2 Mbps. This feature provides the service provider numerous price points, and on the other hand it benefits service provider's customers by allowing them to "pay as you need" without a change in hardware.
- **SLA** - Subscribers connected to a service provider via VCL100MC-1 would be able to obtain Guaranteed Bit Rates (GBR) and Maximum Burst Rates (MBR) that provide specific bandwidth guarantees instead of a "best efforts" service. The SLA parameters would be software provisionable and could be changed by the network operator based on individual SLAs.
- **Enhanced Reliability** - Since Ethernet is transported over SDH, robust SDH protection mechanisms ensure high reliability.
- **Transparent LAN Services (TLS)** - VCL100MC-1 with the Ethernet tributary card allows geographically separated LAN or VLANs to be interconnected.

ETC is source of increased revenue for the service provider, and at the same time reduces the cost of connection per customer

## VCL100MC-1 Applications

### STM-1 Add-Drop Multiplexer

This configuration is used whenever VCL100MC-1 is part of a ring or a linear chain. The box will be configured with two STM-1 optical interfaces (East and West) with E1 drop interfaces. VC-3 and VC-12 level path protection can be offered using SNCP.

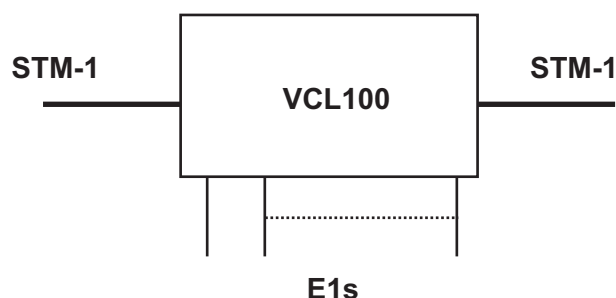

Figure 3: Add-Drop Multiplexer



### STM-1 Terminal Multiplexer

In a terminal multiplexer configuration, only one STM-1 optical interface is used in an unprotected set up. This is the case when VCL100MC-1 is either used as a spur or at the end of a linear segment. If 1+1 MSP is also provisioned, an additional STM-1 optical interface is required on VCL100MC-1.



Figure 4: Terminal Multiplexer

### STM-1 Regenerator

VCL100MC-1 can be configured as regenerator for STM-1 interface without using any tributary slots. The receive clock shall be used in the transmit direction.

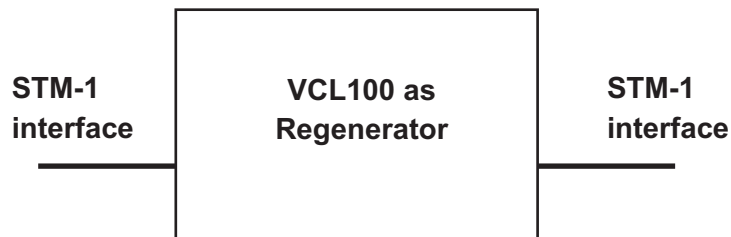

### Network Applications

STM-1 Rings with E1/E3 traffic

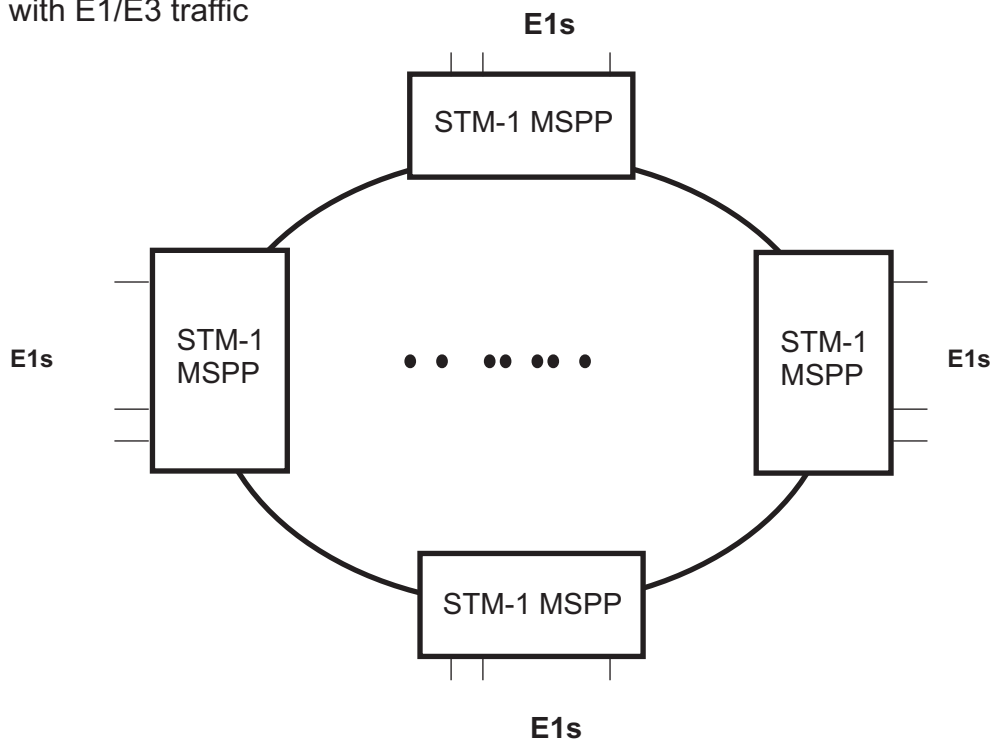

Figure 5: Low Speed backbone

## Transparent LAN service

The VCL100MC-1 ETC card is transparent to all higher layer protocols and provides point-to-point connections between remote Ethernet segments. The ETC is well suited for LAN interconnection services among geographically dispersed corporate offices. Typical LAN interconnection solutions use expensive ATM interfaces on routers to connect to SDH multiplexers. But the 10/100 Base-T interfaces on the VCL100MC-1 SDH node provide a much more cost-effective solution.

### Conventional Solution using ATM interfaces on Routers

Consider connecting 8 subscribers requesting bandwidth of 6 Mbps each. Each router need 8 E3 interfaces for transporting this traffic and this necessitates an STM-4 Backbone.

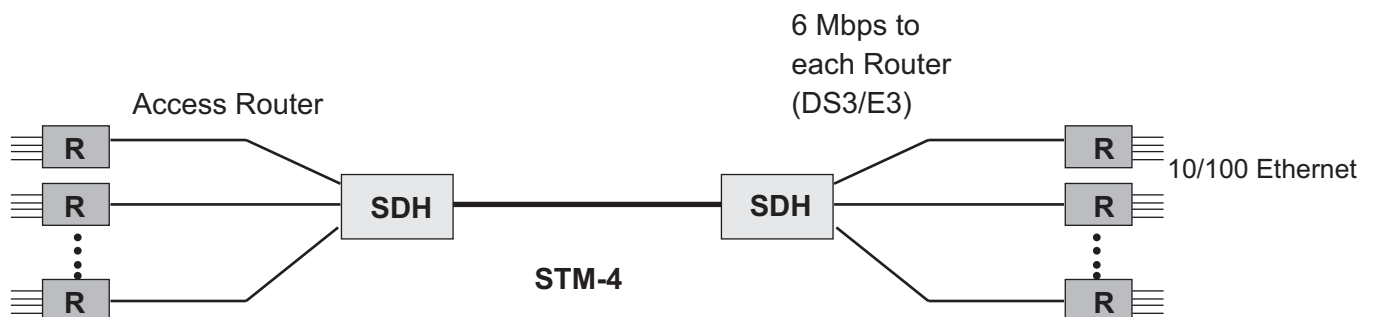

### VCL100MC-1 ETC Solution

In the VCL100MC-1 based solution the traffic from each of these Ethernet connections can be collected using a 10/100Base-T interface on the routers and SDH nodes. The VCL100MC-1 SDH node requires an 8x10/100Base-T ETC card and the traffic from these 8 different connections is flexibly mapped, requiring only an STM-1 Backbone. In addition, upgrading from the existing bandwidth is software -selectable resulting in cost saving in terms of interface cards and operational expenses.

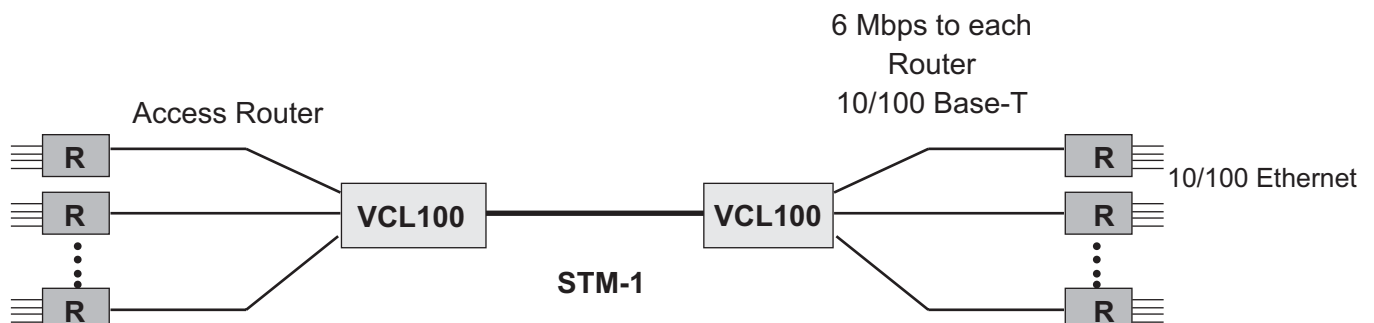

## Integrated Voice and Data Network

In a typical Interconnect Service voice and data traffic from multiple corporate offices need to be interconnected in a cost effective manner. A conventional solution uses separate voice and data networks to carry this traffic over separate fibers. Using the VCL100MC-1 multi-service platform, which provides both TDM and Ethernet interfaces through the ETC, a service provider can carry both voice and data over the same fiber pair using the same equipment.

Example: There is a need to provide data connectivity of 10 Mbps between two locations. There is also a voice traffic requirement of 21E1s between the same two locations. Consider two different distances between the two locations: 10 km and 50 km.

### Conventional Ethernet + SDH solution

In this scenario, data and voice are carried over different fiber pairs using Gigabit Ethernet (GigE) for data

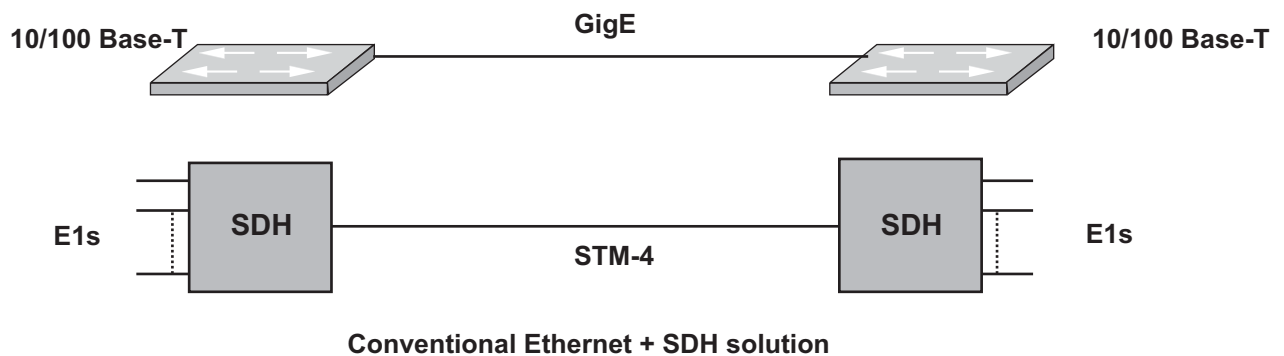

and conventional SDH for voice (Figure 1). Gig LX/HX solution can drive only up to 10 km. GigE ZX solution can provide 70 km spans but is expensive.

### VCL100MC-1 ETC solution

In this solution, data and voice are carried over the same fiber pair by mapping the 10/100Base-T Ethernet traffic onto SDH. The network is a linear SDH network, which can be optionally configured for 1+1 protection. Longer distances can be achieved by using long haul lasers that are relatively much more cost-effective.



# VCL100MC-1 Differentiators

## Software Differentiators

Software forms the core of the VCL100MC-1 platform. Its intelligence enables the VCL100MC-1 products to instantly provision, route, protect, restore, and manage end-to-end circuits.

The point-and-click provisioning tool (PNCP) is a set of software modules that enables customers to provision end-end circuits in a network that comprises all Orion family of SDH products. Users can enable this feature using the node-resident software module NES-NODE-PNCP, and the server resident software module VCLNES-HOST-PNCP.

Some of the highlights of the VCL100MC-1 are the following software features:

- **Automatic Topology Discovery**  
VCL100MC-1 has the ability to automatically discover nodes and trunks within the optical domain, and then intelligently provision the circuit accordingly. This eliminates cumbersome operator intervention and substantially reduces costs.
- **Multi-level Protection Schemes**  
VCL100MC-1 supports the protection schemes for maximum availability. These include line and path level protection schemes like 1+1 MSP with uni/bi-directional switching and SNCP/I. VCL100MC-1 also complies the ITU requirement of MSP and SNCP protection switching times to be within 50 msec. Programmable "Wait to Restore (WTR)" times enable service providers to fine tune circuit restoration times to working path, based on confidence levels.
- **Ethernet over SDH**  
VCL100MC-1 can map Ethernet interfaces, at configurable data rates in increments of E1 starting from 1 E1, directly into SONET/SDH payloads for transport through the optical network. Mapping is performed in a standardized way as per recent ITU-T specifications. Both ITU-T X.86 (LAPS) and G.7041 (GFP) standards are supported.
- **End-to-End provisioning**  
VCL100MC-1 can enable a point-and-click provisioning of E1 level circuits end-to-end, from the access right to the core of an optical network.

## Hardware Differentiators

These are some of the hardware differentiators of VCL100MC-1:

- **Space Efficiency**  
VCL100MC-1 is one of the most compact STM-1 products available in the market, with a 84 E1 capacity drop
- **Modularity and Scalability**  
VCL100MC-1 is a highly modular product adhering to the "pay as you grow" philosophy. This is achieved by providing designing modular cards, which would enable the customers to start small and grow as traffic demands scale.
- **Diverse Topology Support**  
VCL100MC-1 can support diverse topologies like point-to-point, linear and ring with bandwidth-efficient protection mechanisms

## VCL100MC-1 Technical Specifications \*

<b>Network Topology</b>	<ul style="list-style-type: none"> <li>• Linear</li> <li>• Ring</li> </ul>
<b>Network Element Configurations</b>	<ul style="list-style-type: none"> <li>• Terminal Multiplexer (TMUX)</li> <li>• Add Drop Multiplexer (ADM)</li> <li>• Regenerator</li> <li>• STM-1 Cross connect</li> </ul>
<b>Line Side (Aggregate) Optics</b>	<ul style="list-style-type: none"> <li>• 2XSTM-1 1310 or 1550 nm (ITU-T G.957 Compliant)</li> <li>• 2xSTM-1e</li> <li>• S/L 1.1, S/L 1.2</li> </ul>
<b>Tributary Interfaces</b>	<ul style="list-style-type: none"> <li>• E1/DS1/E3/DS3 Electrical</li> <li>• STM-1o</li> <li>• STM-1e</li> <li>• 10/100 Ethernet</li> </ul>
<b>Modularity</b>	<ul style="list-style-type: none"> <li>• Separate tributary cards</li> <li>• Modular in design, capable of tributary upgrades in steps of 21 E1 or 1E3</li> <li>• Mix and match tributaries - E1, E3, DS3, 10/100 Ethernet</li> </ul>
<b>Cross Connect</b>	<ul style="list-style-type: none"> <li>• 252 X 252 VC-12</li> <li>• Fully non blocking</li> <li>• Line to Line, Line to Tributary, Tributary to Line, Tributary to Tributary</li> </ul>
<b>Protection</b>	<ul style="list-style-type: none"> <li>• SNCP/ 1+1 MSP (as per G.841)</li> <li>• VC-12, VC-3 level path protection</li> </ul>
<b>Optional Hardware Redundancy</b>	<ul style="list-style-type: none"> <li>• Power Supply Card</li> </ul>
<b>Maintenance</b>	<ul style="list-style-type: none"> <li>• Higher-order and Lower-order POH, SDH level alarms and performance monitoring (as per G.826 and G.784)</li> <li>• Local &amp; remote loop back</li> <li>• Software Downloads</li> </ul>

<b>Management</b>	<ul style="list-style-type: none"> <li>• VCLNES (VCL Network Element Software), supports full FCAPS functionality via web browser interface.</li> <li>• SNMP interface for NMS</li> <li>• RS-232 port for craft interface</li> <li>• V.24/V.28 Modem interface for remote management</li> <li>• In-band control supported using SDH Overhead</li> <li>• 10/100Base-T/RJ45 management interface</li> <li>• Alarm Signaling Indicators and External Contacts</li> </ul>
<b>Power Supply</b>	<ul style="list-style-type: none"> <li>• Power Input: -48V DC nominal, -36V to 60V DC</li> <li>• Power consumption: less than 20W (for 21E1 configuration)</li> </ul>
<b>Timing &amp; Synchronization</b>	<ul style="list-style-type: none"> <li>• Timing &amp; Synchronization of System (as per G.813)</li> <li>• Internal &amp; External Timing interfaces: Two E1 BITS interfaces (G.703)</li> <li>• Internal oscillator capable of supplying a G.813 compliant Stratum-3 SEC</li> <li>• Support of SSM byte</li> <li>• Accepts/ Provides 2Mbps/2MHz clock references.</li> </ul>
<b>Order wire support and user data channel</b>	<ul style="list-style-type: none"> <li>• E1 / E2 bytes used for Express order wire (Omnibus/Selective calling facilities)</li> <li>• Five potential-free outputs and two potential-free inputs</li> <li>• F1 byte for user data channel</li> </ul>
<b>Physical Dimensions</b>	<ul style="list-style-type: none"> <li>• Dimensions (H X W X D) : 133 mm x 462 mm x 280 mm (5.25 in x 18.2 in x 11 in); Cab be mounted on a 19" or 23" or 600mm rack</li> <li>• Weight: 2.5Kg</li> </ul>
<b>Environmental</b>	<ul style="list-style-type: none"> <li>• Operating Temperature: 0 to 50 C</li> <li>• Relative Humidity: 10% to 90%, non-condensing</li> </ul>

Technical specification are subject to change without notice.  
All brand names and trademarks are the property of their respective owners.  
VCL100MC-1, Revision 02, 1st January 2004