



ORION TELECOM NETWORKS INC.

VCL-EC™

**T1, Voice Echo Canceller
(Upto 10 Echo Cancellers Per Chassis)**

T1, VCL-EC

Product Brochure & Data Sheet

INDEX

S. No.	Particulars	Pg. No.
1	Product Overview	3
2	Features and Highlights	5
3	Application Diagrams	6
4	Front View	9
5	Technical Specifications	10
6	Support	12



Product Overview

Orion Telecom provides robust and cost effective T1 and E1 Echo Cancellers and voice quality enhancement solutions for the long distance, wireline, wireless, (GSM, CDMA), VoIP, satellite and radio communications.



T1 Echo Cancellers - 3U Version (Upto 10 Echo Canceller per Chassis)

The VCL-EC, T1 Echo Cancellers are offered to provide cancellation of 64ms/128ms (user selectable) echo tails. The Echo Canceller equipment is compliant to ITU-T G.164, G.165, G.168 (2000/2002) requirements for echo cancellation.

The Echo Canceller solution offer carrier-grade voice quality per AT&T Voice Quality Assessment Lab. The Echo Canceller supports fax/modem G.164 and G.165 (2100 Hz) tone disable function.

Signaling

The T1 echo cancellers support the following signaling protocols supported: 24B (24 Voice Channels) with out-of-band signaling (C7/SS7 signaling on any user selected time-slot). 23B+D, PRI ISDN (23 Voice Channels+D signaling Channel). Robbed Bit signaling. All signaling options are User Selectable/User Configurable.

Redundancy

The Echo Canceller is equipped to offer redundant power supply (optional).

Remote Monitoring and Control

The equipment offers RS232 serial interface for configuration through a PC COM Port, and an Ethernet (10BaseT) interface for remote LAN configuration and monitoring which allows the user to monitor and configure the equipment over a TCP-IP network from anywhere in the world.

Fault Recovery

The Echo Canceller equipment offers fault recovery feature. It offers automatic by-pass upon power-supply failure/removal power supply. (i.e. it offers T1 circuit by-pass in the event of power supply failure).

Types of T1 Echo Cancellers Offered

User Selectable:

- **128ms** - Unidirectional (cancels the echo with upto 128ms. tail at the far end).
- **64ms** - Bidirectional (cancels the echo with upto 64ms. tail in both directions).

VCL-EC™ Voice Echo Canceller - Technical Highlights

- Provides voice echo cancellation of up to 64ms. bidirectional/128ms. unidirectional - User Selectable/User Programmable.
- Meets ITU-T G.168 (2000/2002) requirements for echo cancellation.
- Signaling protocols supported: 24B (24 Voice Channels) with out-of-band signaling (C7/SS7 Signaling on any user selected time-slot). 23B+D, PRI ISDN (23 Voice Channels+D signaling Channel). Robbed Bit signaling. All signaling options are User Selectable/User Configurable.
- Redundant Power Supply (Optional).
- The Echo Canceller supports fax/modem G.164 and G.165 (2100 Hz) tone disable.
- Offers RS232 serial interface for external PC COM port and Ethernet (10Base-T) interface for remote LAN.
- Automatic by-pass upon power supply failure/removal of power supply.
- Fully integrated independent 24-channels voice echo canceller.

Applications for the T1 Voice Echo Cancellor

Datacomm Applications

- Voice over Frame Relay
- Voice over ATM
- Voice over Internet/LAN (VoIP)

Central Office and PBX Applications

- Network Trunks
- Echo Cancellor Pool
- Common Equipment
- Audio Conferencing Bridges

Voice Over ATM Applications

- A multi-channel echo canceller resource or pool is shared among many channels to reduce cost
- Echo cancellation is done at a DS0 level

Satellite Communications Applications

- Digital Circuit Multiplication Equipment (DCME)

Wireless Applications

- Digital Cordless and Cellular Base stations
- GSM, CDMA
- Access Controllers

Voice Over Frame Relay, ATM Applications

- Frame Relay and ATM routers and switches introduce large, variable and unpredictable delays
- Echoes from the Public Switched Telephone Network (PSTN) in combination with the delays from Frame Relay and ATM equipment yield objectionable speech quality

Quad T1 VCL-EC, T1 Echo Cancellor Advantage

USER PROGRAMMABLE tail-side. Echo Cancellers are always required to be installed, such that, the tail-side of the echo canceller always faces towards the source of the echo. Our T1 Echo Cancellers have a User Configurable tail-side so that the user may remotely change the direction of the tail-side of the echo canceller - without having to physically change the T1 connections on the echo canceller card.

USER PROGRAMMABLE Signaling Option. Our echo canceller provide user programmable. T1 signaling options. The T1 signaling protocols that we support are 24B (24 Voice Channels) with out-of-band signaling (C7/SS7 signaling on any user selected time-slot). 23B+D, PRI ISDN (23 Voice Channels+D signaling Channel). Robbed Bit signaling. All signaling options are User Selectable/User Configurable.

VCL-EC, T1 Echo Cancellers Support 2100 Hz fax/analog data modem tone detection and echo canceller disabling on all channels. For dedicated digital data or video channels, if you wish to assign certain specific time-slots of the T1 circuit for dedicated video you may do so, using our T1 Echo Cancellers. Our T1 Echo Cancellers allow the user to PROGRAM/ASSIGN dedicated time-slots for digital data or video transmission. The user may specify/define the dedicated data channels so that they are always by-passed from the echo cancellation circuitry-leaving those dedicated time-slots for digital data communication/dedicated video transmission only.

USER PROGRAMMABLE dedicated data channels. The user may specify/define the dedicated data channels so that they are always and completely by-passed from the echo cancellation circuitry - leaving those specifically assigned dedicated time-slots for digital data transmission (including video transmission).

VCL-EC, T1 Voice Echo Cancellor - Features and Highlights

- User Selectable - 128ms.-unidirectional or 64ms.-bidirectional. The user selection is made through a user configurable software interface command
- Compliant to ITU-T G.164, G.165, G.168 2000, G.168 2002) requirements
- Carrier-grade voice quality per AT&T Voice Quality Assessment Lab
- Fax/Modem G.164, G.165 - 2100 Hz tone disable as per ITU-T G.164/G.165 Recommendations. Allows fax and analog modem data transmission through automatic echo cancellation enable/disable function
- Disable Tone detection supported on all audio paths
- Fully integrated independent 24-channels voice echo canceller
- Option for user to select data or voice channels for selective echo cancellation. This feature allows the user to use selected time-slots for data transmission to enable digital data/CCS signaling transmission
- Transmission (data mode), while keeping the echo cancellation "ON" on the remaining time-slots (voice mode), on which echo is required to be cancelled
- T1 circuit by-pass in event of power supply failure. This feature enables the by-pass of the T1 circuit in the event of power failure. This ensure continuous signal even if the power to the echo-canceller fails
- T1 circuit by-pass on power failure
- T1 circuit by-pass on echo canceller card removed. This feature allows the user to by-pass the T1 circuit by simply removing the echo-canceller card. T1 circuit connects "through" as soon as echo-canceller is removed from its slot.
- Non-linear processor with adaptive suppression threshold and comfort noise insertion
- Programmable double-talk detection threshold.
- Narrow-band signal detection
- Adjustable gain/loss settings on all channels. Provides the user the flexibility to adjust and optimize the voice and transmit receive levels disable function
- Signaling Support:
 - 24B (24 Voice Channels) with out-of-band signaling
 - C7, SS7 signaling
 - 23B+D, PRI ISDN (23 Voice Channels+D signaling Channel)
 - Robbed Bit signaling (on any user selected time-slot).
 - All signaling options are User Selectable/User Configurable
- Redundant Power Supply (Optional)
- Non-Linear Processor with Comfort Noise Insertion
- TCP/IP remote access for remote configuration and control
- Assures operability with V.32/V.32bis/V.34 modem and fax transmissions. Conforms to standards assuring proper public network operation and facilitating system integration
- Removes residual echo and minimizes switching effects thereby providing high perceived speech quality. Unique design provides the industry's best sounding single chip echo canceller
- Ensures echo canceller maintains excellent performance at all times in the presence of non-echo voice signals. Useful for trunks that have very low echo-returns loss
- Ensures echo canceller maintains excellent performance at all times in presence of tones or signals including DTMF tones
- Instability detector suppresses variable pitched ringing or oscillation
- Path change detect permits fast re-convergence when a major change occurs in the echo channel
- User selectable tail-end side. This feature allows the user to select the "tail-end" side of the echo canceller. The "tail-end" side of echo canceller is that part of the network which generates/causes to generate the echo. Unidirectional echo cancellers must always be installed on far-end of any network from the point at which an echo is being heard. The "tail-end" side must always face the "Source Side" of the network which is generating the echo. Ideally suited to handle most echo situations
- Usable in telecommunications systems worldwide. Able to interface in most systems where linear samples are available

Application Diagrams

Application 1

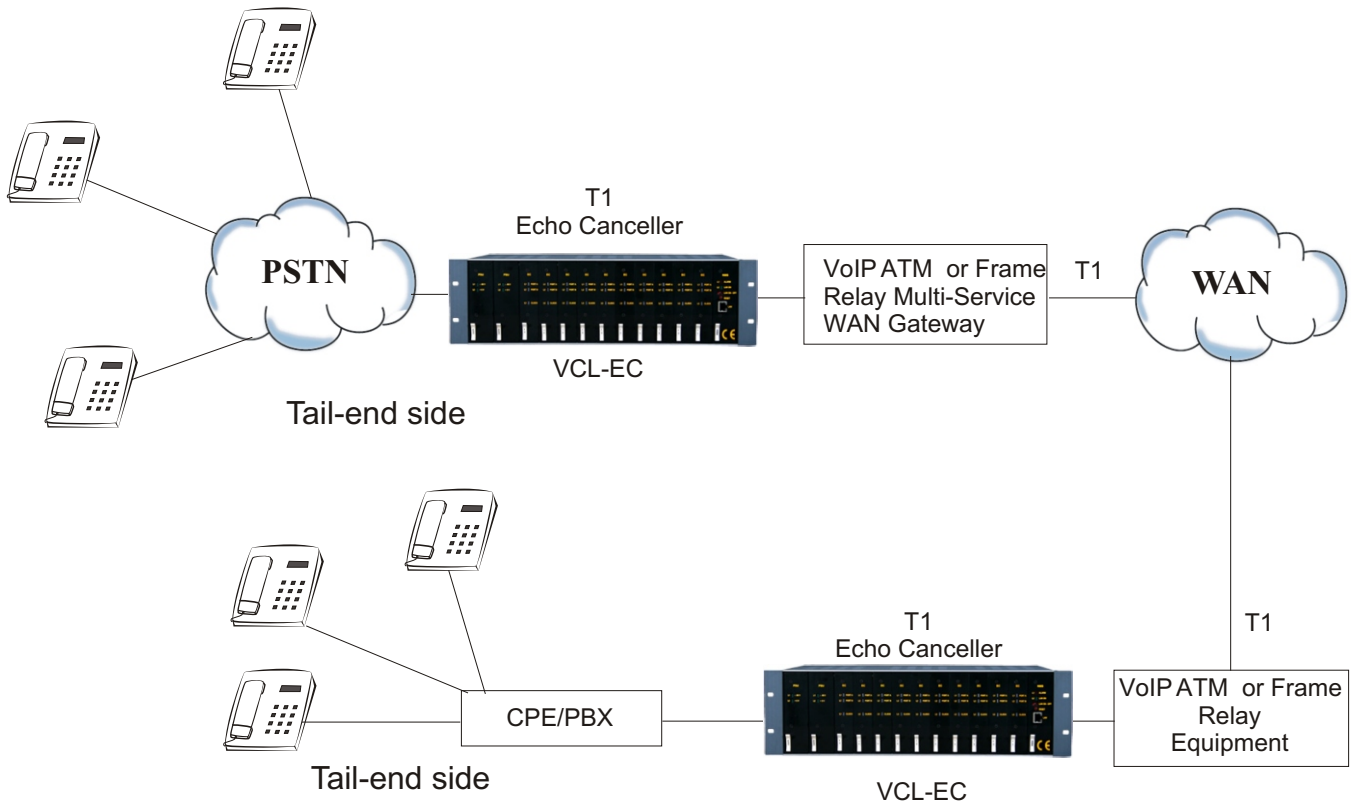

To cancel the echoes at both ends of the network with two 128ms. unidirectional echo cancellers

Application 2

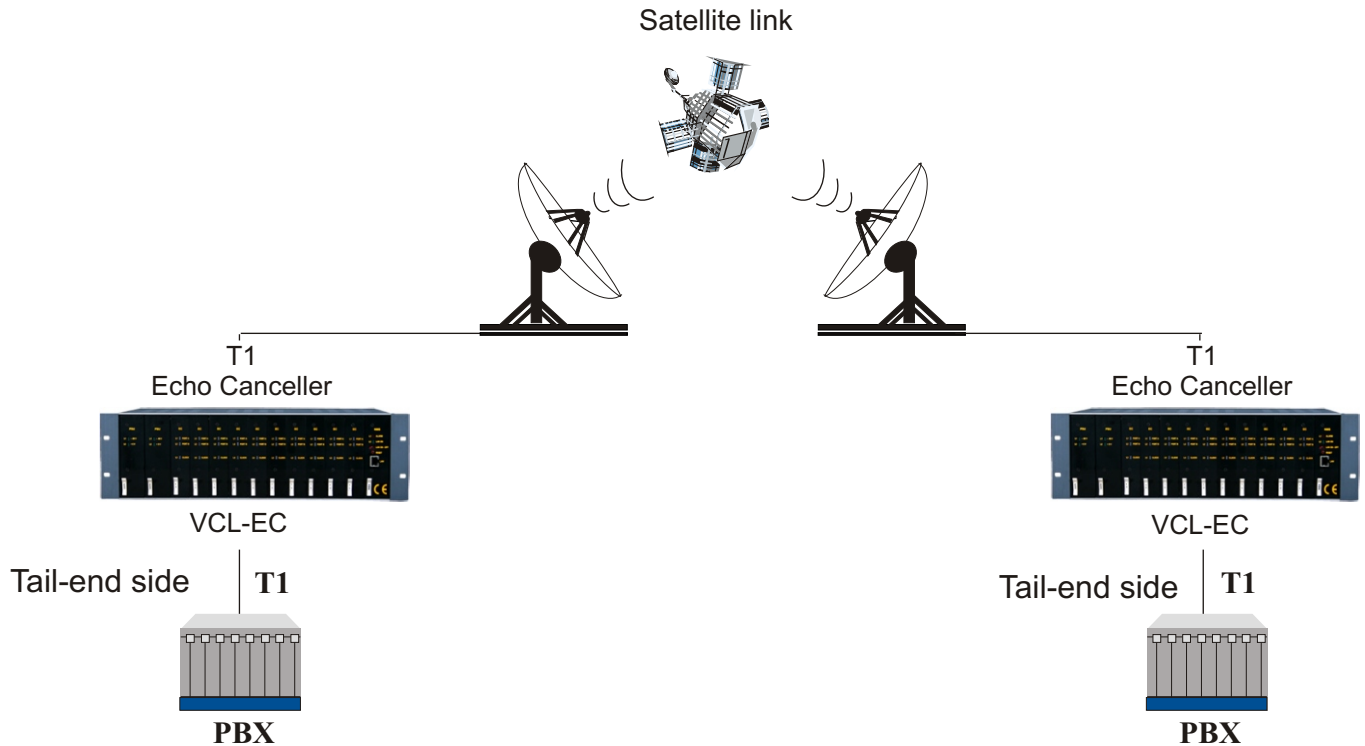

To cancel the echoes at both ends of the network with two 128ms. unidirectional echo cancellers

Application 3

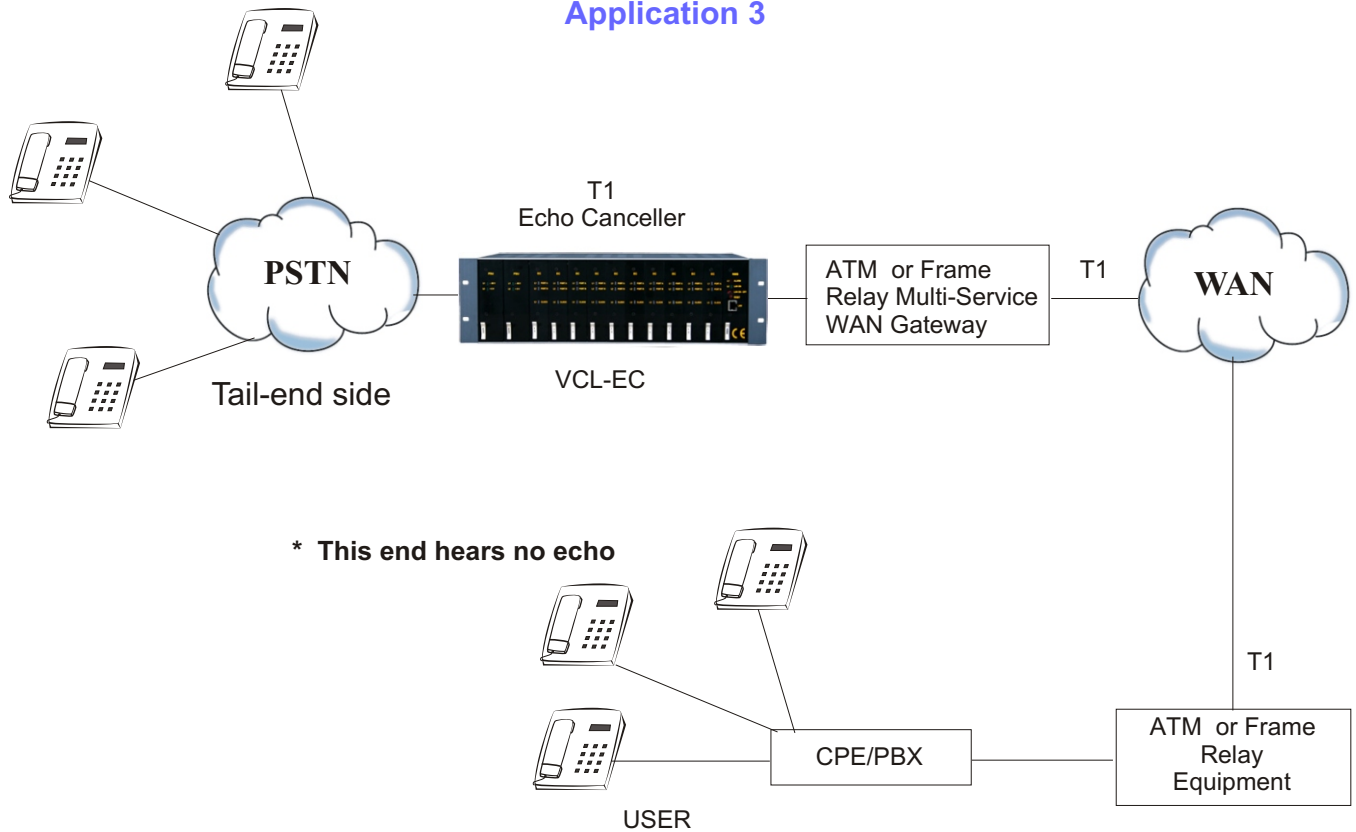

To cancel the near-end echo with one 128ms. unidirectional echo canceller

Application 4

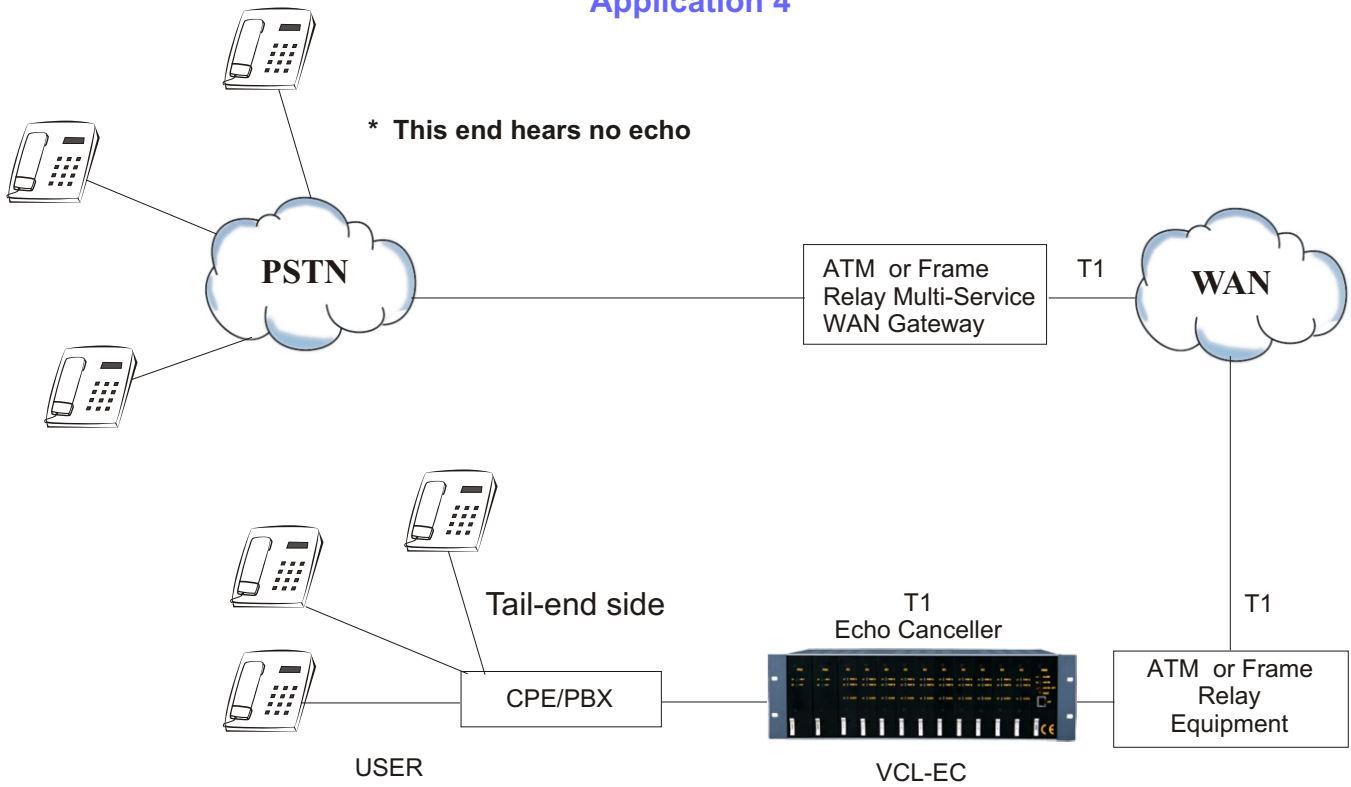

To cancel the far-end echo with one 128ms. unidirectional echo canceller

Application 5

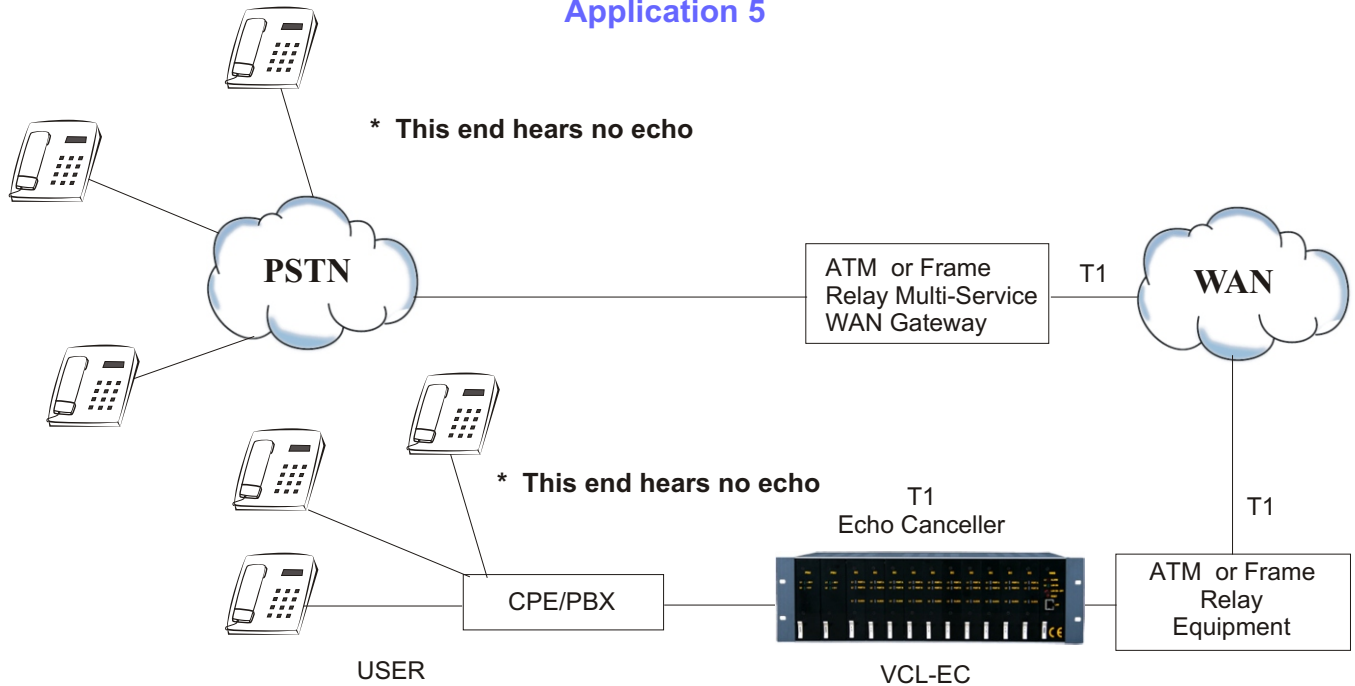

To cancel echoes at both ends of the network with one 64ms. bidirectional echo canceller

**VCL-EC, T1 Voice Echo Cancellor
Shelf Description:**

The VCL-EC, T1 Voice Echo Cancellor is a 3U, 19 inch shelf, fitted with a back plane that provides rear access of all external interfaces. The T1 interface, power input, alarm extension are all accessed from the system back plane.

VCL-EC, T1 Voice Echo Cancellor

Front View of the Shelf

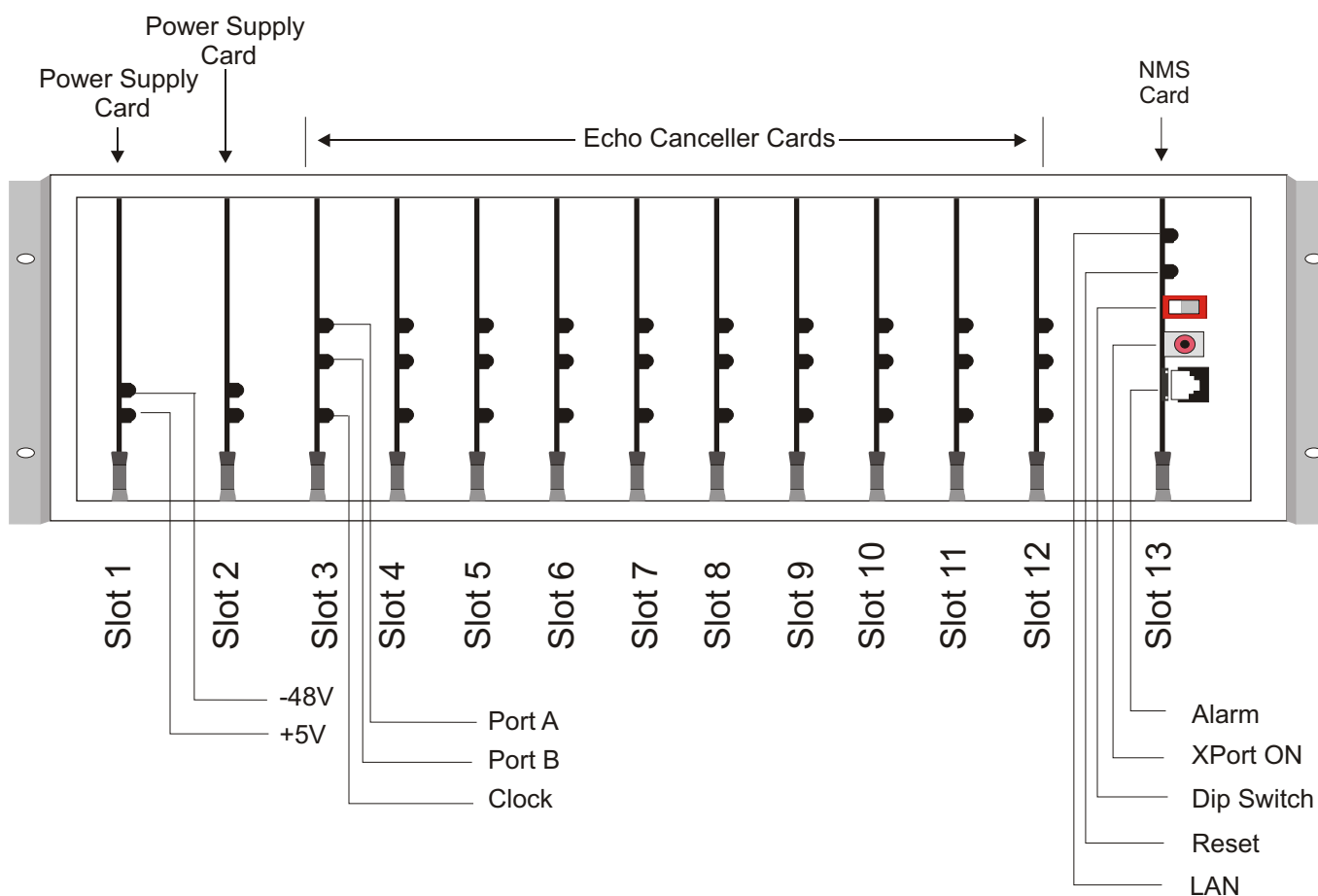

Front View (Left to Right)	Card Details	Orion Part No.
Backplane/Chassis	19-inch shelf - 3U High (sub-rack)	VCL-EC1274-100-Ohms
Slot 1	PS, Power Supply Card	VCL-EC-1295-PS
Slot 2	PS, Power Supply Card (Redundant/Optional)	VCL-EC-1295-PS
Slot 3 to Slot 12	EC, Echo Cancellor Card (64ms/128ms Echo Cancellation)	VCL-EC-1273-T1
Slot 13	NMS Card	VCL-EC-1222-NMS

Technical Specifications

T1 Interface at 1544 Kbps

Network Interface

Number of Interfaces	2, 1-Input (RJ-45), 1-Output (RJ-45)
Line Rate	T1 - 1.544 Mbps
Line Code	B8ZS, AMI (User Selectable)
Frame Structure	D4, ESF (User Selectable)
PCM Encoding Law	Mu Law as per ITU-T G.711
Signaling	Pass-through signaling protocols supported: - 24B (24 Voice Channels) with out-of-band signaling - C7/SS7 signaling on any user selected time-slot - 23B+D, PRI ISDN (23 Voice Channels+D signaling Channel). - Robbed Bit signaling. - All signaling options are User Selectable
PCM Sampling Rate	8000 samples/sec
Bit Rate	1544 Kbps \pm 50 ppm
Jitter Tolerance	As per ITU-T G.823
Output Jitter	< 0.05 UI (in the frequency range of 20Hz to 100 KHz)
Nominal Line Impedance	100 Ohms Balanced RJ 45
Nominal Pulse Width	244 ns
Pulse Mask	as per ITU (CCITT) Rec. G.703
Loss and recovery of frame alignment	As per clause 3 of ITU (CCITT) G.732
Loss and recovery of multiframe alignment	As per clause 5.2 of ITU (CCITT) G.732

Echo Cancellation

Echo Tail Cancellation	Up to 64ms. bidirectional/128ms. unidirectional - User Selectable
Tone Disabler	As per ITU-T G.164, G.165
ERLE (Echo Return Loss Enhancement)	>35dB (with 6dB ERL) at -10dBm0 input >65dB with NLP enabled
ERL (Echo Return Loss)	Selectable Levels Options: 0, 3, 6 dB
Transmit/Receive Levels (Programmable)	Selectable Levels Options: -12, -9, -6, -3, ,0 +3, +6, +9
Comfort Noise Insertion	User Selectable - ON/OFF
Local Monitoring and Control	RS232 serial interface for Management through a PC COM Port
Remote Monitoring and Control	Ethernet (10BaseT) interface for remote LAN Management and Control
Local and Remote Provisioning	CLI (text commands) and GUI
Front Panel Indicators	- In SYNC/Failure - Equipment alarm - LEDs for power on/off
Power Supply Redundancy	Optional: -48VDC Power Supply (1+1)
Environmental - Operational	0 C to 50 C
Humidity	5% to 95%, non-condensing

Clock

Internal	(Stratum 3 level)
Loop-timed	Port A/Port B (User Selectable)

Power Supply Specifications

Input DC Voltage	-48V DC (nominal)
Range of Input Voltage	-40V to -60V DC
Output Voltages	+5V
Maximum Full Load Output Current	10A at +5V
Input Voltage Reversal Protection	Provided in the Card
Over Current Protection	> 10A for +5V
Short Circuit Protection	Current limit - 10A. Recovers on removal of short circuit
Under Voltage	< 4.5V
Over Voltage	5.4V
Efficiency at Full Load	>86%
Ripple at Full Load	<5mVrms
Spike at Full Load	<50mV

Management Port Specifications RS232 COM Port

Serial Port: 9.6Kbps (Async). ASCII / VT100 / HyperTerminal.
10BaseT Ethernet: Telnet

Power Consumption of T1 Echo Cancellers

Card in Use	Current (in Amps.)	Power Consumption (in Watts)
Input Voltage = - 48 Volt		
1 EC Card + PSU Card + NMS Card	0.15	6.0
10 EC Cards + PSU Card + NMS Card	0.825	39.6

Management Port Specifications 10BaseT LAN Management Port (with Telnet)

Network Interface	RJ-45 Ethernet 10BaseT or 100BaseT-TX (auto sensing)
Compatibility	Ethernet Version 2.0 IEEE802.3
Protocols Supported	ARP, UDP/IP, TCP/IP, Telnet, ICMP, SNMP, DHCP, BOOTP, TFTP, Auto IP, SMTP and HTTP
LEDs	10Base-T and 100Base-TX Activity, Full/half duplex.
Management	Serial login, Telnet login, GUI (Graphical User Interface)
EMI Compliance	<ul style="list-style-type: none"> - Radiated and conducted emissions - complies with Class B limits of EN 55022:1998 - Direct and Indirect ESD - complies with EN55024:1998 - RF Electromagnetic Field Immunity - complies with EN55024:1998 - Electrical Fast Transient/Burst Immunity - complies with EN55024:1998 - Power Frequency Magnetic Field Immunity complies with EN55024:1998 - RF Common Mode Conducted Susceptibility complies with EN55024:1998

Mechanical Specifications

Rack Mounting	Standard 19 Inch. DIN Rack
Height	133.33 mm.
Depth	292 mm.
Width	482 mm.
Weight	7.50 kg. (10, Echo Cancellers)

Compliance/Regulatory

<ul style="list-style-type: none"> • EMC FCC Part 15 Class 2
<ul style="list-style-type: none"> • Operation ETS 300 019 Class 3.2
<ul style="list-style-type: none"> • Storage ETS 300 019 Class 1.2
<ul style="list-style-type: none"> • Transportation ETS 300 019 Class 2.3
<ul style="list-style-type: none"> • CE

Shelf Description

Backplane/Chassis	19-inch shelf - 3U High (sub-rack)	VCL-EC1274-100-Ohms
Slot 1	PS, Power Supply Card	VCL-EC-1295-PS
Slot 2	PS, Power Supply Card (Redundant/Optional)	VCL-EC-1295-PS
Slot 3 to Slot 12	EC, Echo Canceller Card (64ms/128ms Echo Cancellation)	VCL-EC-1273-T1
Slot 13	NMS Card	VCL-EC-1222-NMS

Technical specifications are subject to changes without notice.
 All brand name and trademarks are the property of their respective owners.
 Revision 12 - June 18, 2008

E-mail: sales@oriontelecom.com
 Web Site: <http://www.oriontelecom.com>