



ORION TELECOM NETWORKS INC.

E1-GSMTM

**E1 Channel Bank with
30 X GSM Wireless Interface(s)**

- **Product Overview**
- **Features & Highlights**
- **Ordering Information**
- **Product Specifications**
 1. **E1 Interface**
 2. **GSM Interface**

Headquarters: Phoenix, Arizona

Orion Telecom Networks Inc.

20100, N 51st Ave, Suite B240,
Glendale AZ 85308

Phone: +1 480-816-8672

Fax: +1 480-816-0115

E-mail: sales@oriontelecom.com

Website: <http://www.oriontelecom.com>

Regional Office: Miami, Florida

Orion Telecom Networks Inc.

4000 Ponce de Leon Blvd. Suite 470,
Coral Gables, FL 33146 U.S.A.

Phone: 1-305-777-0419,

Fax: 1-305-777-0201

E-mail: sales@oriontelecom.com

Website: <http://www.oriontelecom.com>

PRODUCT OVERVIEW

Orion presents a breakthrough in technology by integrating the WAN E1 interface to the GSM mobile communications network. Orion's GSM Channel Bank is a compact wireless solution, which integrates the E1 interface to the GSM (wireless) network to provide the USER with 30, GSM (mobile) wireless links for mobile communications with an integrated E1 Interface

- The interface of the Network Side is E1 Digital Interface with CAS R2 Signaling.
- PRI ISDN (EURO ISDN) Signalling (Optional).
- Ideal choice for terminating long distance traffic / VoIP / VoFR or DCME traffic to the PSTN / GSM (mobile cellular) networks. No LAND LINES REQUIRED!!!
- The interface on the USER Side is 30 x GSM Wireless links.
- Remote monitoring and configuration through TCP/IP access.
- Unique out-bound calling user programmable access feature.

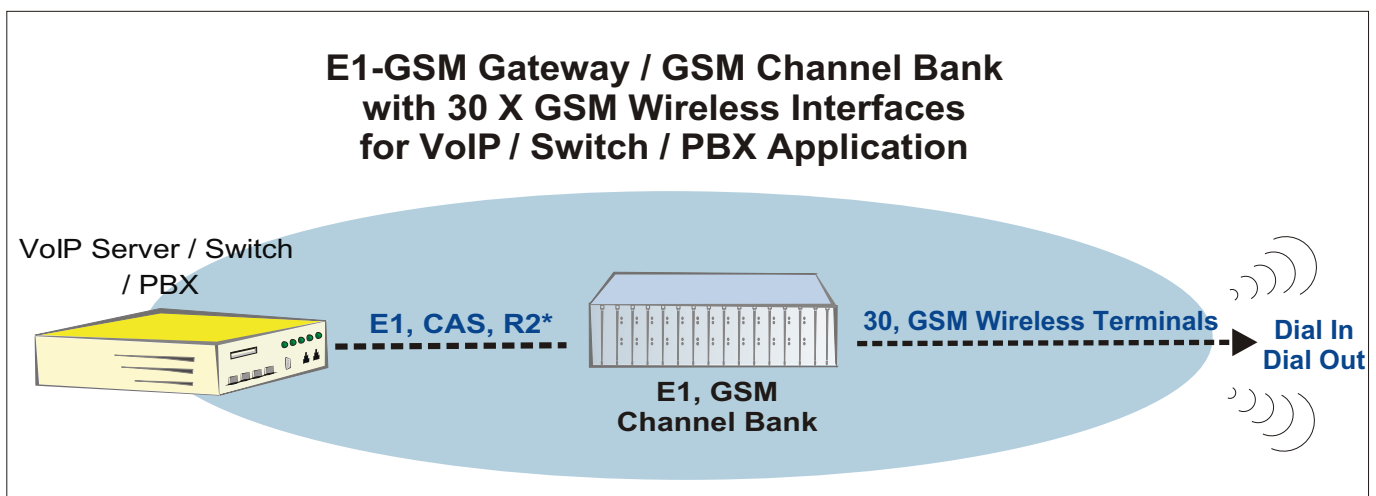

*PRI ISDN (EURO ISDN) Signalling (Optional).

FEATURES & HIGHLIGHTS

- Compact, 30 GSM wireless terminals in a 19-inch chassis.
- GSM is integrated to the E1 Interface. No gray areas of what will work with what. Tested to work with Cisco 3600 and Cisco 5300 VoIP Servers (and many others). Please contact the factory for the exhaustive compatibility list.
- Improved voice quality. The two wire trans-hybrid analog path (present in the Fixed Wireless terminals) is eliminated in the Orion GSM design resulting in improved voice quality, clearer voice and superior channel separation by reducing the susceptibility to echoes that result from the analog two wire trans-hybrid VF paths.
- Disable caller ID. Orion's GSM terminal can be programmed (default factory setting) to block caller ID presentation, if allowed by the local GSM Network.
- Provides accurate billing information ("answer supervision" and "line disconnect supervision") - not provided by Nokia Fixed Wireless Terminals and optional in Telular Fixed Wireless Terminals.
- Integrated, optional, E1 Echo Canceller to cancel echo-tails from inherent delays of VoIP, VoFR Networks 64ms - unidirectional, 128ms - unidirectional and 64ms - bidirectional options available.
- Lower cost - resulting from complete, GSM wireless to E1 integration.
- Ideal choice for terminating long distance traffic / VoIP traffic to the PSTN / GSM (mobile cellular) networks. No LAND LINES REQUIRED!!!
- Plug-And-Play. Easy to install. Takes only minutes to install and start service.

<p>Orion's Integrated E1 / T1 GSM Channel Bank - PROS</p> <ol style="list-style-type: none"> 1. Integrated and Compact. 24 (T1), or 30, (E1) GSM channels in a compact 6U high, 19-inch rack-mountable shelf. 2. Integrated, Single Power Input: -48VDC or AC Mains. Both options are provided. 3. 3.5dB gain, external antennas with 2 meter Rg174 cable and antenna trays. Easy to manage. 4. Offers Remote and Integrated Graphical User Interface (GUI) Management to monitor all GSM channels. This option allows the USER to view and monitor the status of ALL 24 / 30 GSM channels, including FAULTS on any of the individual GSM channels, remotely, over a TCP-IP network. 5. Integrated, 64ms. and 128ms. Echo-Canceller option. This option allows the USER to install a 64ms. / 128ms. Echo-Canceller in the same 19-inch chassis, to effectively remove any echoes resulting From VoIP and VoFR network delays. 6. Direct E1 - A Law to GSM Conversion, or, Direct T1 Mu Law to GSM conversion, with patented (patent pending) noise reduction technology. Greatly improves voice quality and voice clarity. 	<p>Third Party, component solutions comprising of E1 / T1 Channel Banks and 24 (T1) / 30 (E1) Fixed Wireless Terminals - CONS</p> <ol style="list-style-type: none"> 1. Discreet and poorly managed solution comprising of a channel bank and discreet and 24 (T1) / 30 (E1) Fixed Wireless Terminals. 2. Individual, 24 (T1) / 30 (E1) Fixed Wireless Terminals with 30, separate power inputs. Difficult to manage. 3. Absence of External Antennas provides no additional signal gain. 4. No management facility to monitor the GSM terminals remotely, or to view the channel or fault status on any of the GSM channels. 5. No option of ANY Echo-Canceller, which are often essential and required in VoIP and VoFR call termination, owing to unacceptable echoes which often result from network delays. 6. Poor coupling of analog lines (from the E1 / T1 channel banks) to GSM Fixed Wireless Terminals often results in the analog lines picking up a lot of GSM transmission noise often resulting in unacceptable voice quality and poor quality service.
---	--

Orion's Integrated E1 / T1 GSM Channel Bank - PROS

7. Unique dial-out, user programmable access. USER PROGRAMMABLE, call directory interface. This optional feature, unique to Orion E1 / T1, GSM Multiplexer, allows the USER to program "out-bound" calls (GSM Network to E1 / T1), to be restricted to a list of USER pre-programmed numbers only. This feature can be used to provide limited access to out-going calls (GSM Network to E1 / T1), on dedicated channels, which the service provider may wish to RESERVE only for its SUBSCRIPTION CUSTOMERS wishing to use out-bound long-distance services (GSM Network to E1 / T1), through VoIP / VoATM networks.

This option also allows the USER to RESTRICT, or to ALLOW all calls originating from the GSM Network to E1 / T1 VoIP / VoATM Gateway.

8. Accurate CALL METERING resulting from accurate answer-supervision and line-disconnect supervision since the integrated E1 / T1, GSM Channel Bank derives its answer-supervision (required for the call-metering function), from the SS7 based GSM Network Signaling / GSM Switch.
9. Greater product reliability. Integration results in greater product reliability and results in less downtime resulting from a low failure rate.
10. Low Cost. Integration also results in cost reduction when compared with a component based, discreet solution comprising of a T1 / E1 channel bank PLUS 24 / 30 Fixed Wireless Terminals.

Third Party, component solutions comprising of E1 / T1 Channel Banks and 24 (T1) / 30 (E1) Fixed Wireless Terminals - CONS

7. No USER PROGRAMMABILITY to RESTRICT or ALLOW calls based a USER PROGRAMMABLE directory. No such feature is provided, or offered in the Fixed Wireless Terminal Channel Bank solution.
8. Unreliable CALL METERING resulting from a battery reversal based, or VAD based (Voice Activated) answer supervision, which is based on analog technology and prone to errors. A VAD based answer supervision offers unreliable CALL METERING, in comparison with the integrated E1 / T1, GSM Channel Bank which derives its answer-supervision (required for the call-metering function), from the SS7 based GSM Network Signaling / GSM Switch.
9. Poor product reliability resulting from low integration, poor management and a high number of individual components that are required to be managed (24 or 30 individuals Fixed Wireless Terminals, each with separate power supplies, and the channel bank.
- 10 Higher cost. The cost appears to be even higher, the absence of any available features, and if poor product management, poor product integration resulting in lower product reliability is taken into consideration.

PRODUCT SPECIFICATIONS

Technical Specifications

E1 Interface Card

Number of E1 Interfaces	One
Conformity	G.703
Frame Structure	As per ITU-T (CCITT) G.704
Signaling	Channel Associated Signaling (R2 Generic) in accordance with ITU-T Q.421, and ITU-T Q.422 Complies to both ITU-T Q.421, and ITU-T Q.422. *PRI ISDN (Euro ISDN) Signaling optional Extra
PCM Sampling Rate	8000 samples / second.
Encoding Law	A Law
Bit Rate	2048Kbps 50ppm.
Code	HDB3
Nominal Impedance	120 Ohms Standard (75 Ohms Optional)
Connector	RJ45 (120 Ohms Impedance)
Peak Voltage of a mark For 120 Ohms Balanced Interface	3.0 Volt 0.3 Volt.
Pulse Mask	As per ITU-T (CCITT) Rec. G.703
Output Jitter	<0.05UI (in the frequency range of 20Hz to 100KHz).
Permissible Attenuation	6dB at 1MHz
Return Loss at:	
51.2 KHz to 102.4 KHz.	> 12dB
102.4 KHz to 2048 KHz	> 18dB
2048 KHz to 3072 KHz	> 14dB
Jitter Tolerance	As per ITU-T (CCITT) G.823
Loss and Recovery of Frame Alignment	As per Clause 3 of ITU-T (CCITT) G.732
Loss and Recovery of Multi-Frame Alignment	As per Clause 5.2 of ITU-T (CCITT) G.732

Power Supply Card

Input DC voltage	-48V DC (nominal)
Range of input	-40V to -60V DC
Output voltages	+5V
Full Load Output Current	18A@5VDC
Input Voltage Reversal Protection	Provided in the Card
Over Current Protection	20A for +5V
Short Circuit Protection	Current limit - 20A. Recovers on removal of short
Under Voltage	< 4.5V
Over Voltage	5.4V to 5.6V
Efficiency at full load	>80%
Ripple at full load	<5mVrms
Spike at full load	<50mV
Power Consumption	120 Watts (Worst Case)

GSM Access Card

Number of GSM Interfaces	1 ~ 30 (Stackable, 1 thru 30).
Type	Dual Band EGSM 900 MHz and EGSM 1800 MHz.
Compliance	Compliant with ETSI GSM Phase 2+ standard (Normal MS) Class 4 (2W @ 900MHz) Class 1 (1W @ 1800 MHz)
Approvals	Fully Type Approved to GSM Standards
SIM Interface Internal Tray	Toolkit Class 2. 3V Reader
Voice Features	Full Rate, Enhanced Full Rate And Half-Rate (FR/EFR/HR)
DTMF	Dual Tone Multi FrequencyFunction (DTMF) Dialing Support

Alarms

An alarm shall be displayed in LED L1 / L2 for the following reasons

1. Invalid SIM Card
2. Unregistered SIM Card
3. Faulty SIM Card
4. Faulty GSM Module
5. GSM Access Card Out of Range

Echo Canceller Card

- Provides voice echo cancellation of up to 64ms / 128ms
- Conforms to ITU-T G.165 and ITU-T G.168
- G.164 /G.165 disable tone detection
- Non-Linear Processor with Comfort Noise Insertion
- Narrow-Band Detector
- Eliminates long echo tail.

E1 Echo Canceller - E1 Interface (Optional)

Number of Interfaces	2, 1 - Input 1 - Output
Conformity	G.703
Frame Structure	As per ITU (CCITT) G.704
Signaling	Pass-Through
PCM Sampling Rate	8000 Samples / sec
Encoding Law	A Law as per ITU (CCITT) G.711
Bit Rate	2048 Kbps \pm 50 ppm
Code	HDB3
Nominal Impedance	120 Ω balanced
Peak Voltage of a mark For 120 Ω Balanced interface	3.0 V \pm 0.3 V
Peak Voltage of a space for 120 Ω Balanced interface	0 V \pm 0.3 V
Nominal Pulse Width	244 ns
Pulse Mask	as per ITU (CCITT) Rec. G.703
Output Jitter	< 0.05 UI (in the frequency range of 20Hz to 100 Khz)
Permissible Attenuation	6 dB at 1 MHz
Return Loss at:	
51.2 KHz to 102.4 Khz	> 12dB
102.4 KHz to 2048KHz	> 18dB
2048KHz to 3072 Khz	> 14dB
Jitter Tolerance	As per ITU (CCITT) G.823
Loss and recovery of frame alignment :	As per clause 3 of ITU (CCITT) G.732
Loss and recovery of multiframe alignment :	As per clause 5.2 of ITU (CCITT) G.732

Mechanical Specifications:

Rack Mounting	Standard 19-Inch DIN Rack
Height	6U (265 mm)
Depth	290 mm
Width	19-inch (477mm)
Weight	12Kgs. (Net)

Ordering Information

Sr. No.	Part No.	Product Description	Qty
1.	E1-015	Control Card, E1 Interface Card	01
2.	E1-000 / 005	19" Shelf 3U High (Sub-rack) to accommodate 30 GSM Channels with Connectorized Backplane 6U High	01
3.	E1-010	(-) 48VDC Power Supply Card	02
4.	E1-030	Dual Port GSM Interface Card - GSM terminals connect to an E1 interface, 15 Cards (max) per system	15 (max.)
5.	E1-030-ANT	External Antennas with 2 Meter Connectorized cable	30
6.	E1-01048-150W	Power Supply (External) AC to DC Converter Portable External Converter Universal AC Input [93VAC-276VAC, 47Hz-63Hz] to DC Output [(-) 48VDC]	01

Common Equipment

Optional

7.	VCL-EC64-U	E1 Echo Canceller Card, provides 64ms of unidirectional echo cancellation. 1 Card required for every E1-GSM Shelf	01
8.	VCL-EC128-U	OR E1 Echo Canceller Card provides 128ms of unidirectional echo cancellation. 1 Card required for every E1-GSM Shelf	01

Optional

9.	E1, VCL-TCP-IP	TCP-IP remote access for configuration Option allows the user to access, configure and control the E1-GSM / Channel Bank equipment over a TCP-IP network. 1 Required for every E1-GSM Shelf	01
----	----------------	---	----

Technical specification are subject to change without notice.
 Windows is the registered Trademark of Microsoft Corporation, USA.
 All brand names and trademarks are the property of their respective owners.
 Revision 02. 01 July 2005.