



ORION TELECOM NETWORKS INC.

VCL-EC-DS3™ Voice Quality Enhancement (VQE) & Echo Canceller

DS3 VQE & Echo Canceller

Product Brochure & Data Sheet

Headquarters: Phoenix, Arizona

Orion Telecom Networks Inc.

20100, N 51st Ave, Suite B240,
Glendale AZ 85308
Phone: +1 480-816-8672
Fax: +1 480-816-0115
E-mail: sales@oriontelecom.com
Website: <http://www.oriontelecom.com>

Regional Office: Miami, Florida

Orion Telecom Networks Inc.

4000 Ponce de Leon Blvd. Suite 470,
Coral Gables, FL 33146 U.S.A.
Phone: 1-305-777-0419,
Fax: 1-305-777-0201
E-mail: sales@oriontelecom.com
Website: <http://www.oriontelecom.com>

INDEX

S. No.	Particulars	Pg. No.
1	Product Overview	3
2	Key Highlights	3
3	Echo Tail Displacement (echo tail off-set)	4
4	Applications	5
5	Features and Highlights	6
6	Front View	8
7	Technical Specifications	10
8	Ordering Information	11
9	Support	12



Product Overview

Orion offers the industry's most compact DS3 Voice Quality Enhancement (VQE) echo canceller solution in a 19-inch, 3U (44mm height) chassis, with echo tail-displacement (echo tail off-set) feature which is user programmable from 0 ms. to 512 ms. Echo cancellation on each channel is 128 ms. bidirectional (near-end and far-end). The DS3 VQE and echo canceller solution offers a unique, user definable echo-tail displacement feature which may be programmed by the user, between 0 ms. to 512 ms. on the return path to cancel echo-tails, both at the near-end and the far-end, even in the most demanding network conditions.



DS3 VQE and Echo Canceller

Orion offers echo cancellation and voice quality enhancement solutions for the following network situations:

- Wireline
- International Gateway
- IP Gateway
- Wireless
- Satellite

These solution are also an ideal echo cancellation solution for long distance telephony, GSM, CDMA, TDMA, VoIP, satellite and radio communication applications.

The VQE and echo canceller equipment is compliant with ITU-T G.164, G.165, G.168 (2000/2002) and G.169 requirements for echo cancellation. The echo canceller solutions offer carrier-grade voice quality per AT&T Voice Quality Assessment Lab. Echo cancellation on each channel is 128 ms. bidirectional.

Key Highlights

- Orion offers the most compact DS3 Echo Cancellers and Voice Quality Enhancement (VQE) Solution for the industry.
- 128 ms. bidirectional (near-end and far-end) echo cancellation with echo-tail displacement from (tail off-set) 0 ms. to 512 ms.
- Programmable Echo-Tail Displacement (echo tail off-set) from 0 ms. to 512 ms.
- Echo tail displacement allows user to program a delay off-set on return path and the user can cancel near-end and far-end echo from single installation.
- Ideally suited for GSM Networks to eliminate “background noise” to enable GSM Networks to function at half-rate (HR) with full rate voice quality thereby doubling spectrum usage in GSM Networks.
- Echo Cancellation on each channel is 128 ms. bidirectional (near-end and far-end).
- Compliant with ITU-T G.164, G.165, G.168 (2000/2002) and G.169 requirement for echo cancellation.
- Electrical echo cancellation resulting from networks delays and delays arising due to complex voice compression algorithms in hybrid PSTN and long distance networks.
- Acoustic echo cancellation required for mobile networks for cancelling echo-tails that originate from cellular hand-sets designed with poorly designed acoustic feedback.
- Programmable echo-tail displacement (near-end and far-end) from 0ms. to 512 ms.
- Auto Voice Level Control and VQE (Voice Quality Enhancement features) required for reducing background noise from calls originating from crowded public places or other noisy environments and maintaining a uniform voice level in a network. Improves voice quality.
- User programmable dedicated data channels.
- Remote access through telnet.
- DS3 VQE echo cancellers in a 3U (44mm) high chassis industry’s smallest foot print.
- User Programmable signaling options.
- PRI ISDN (23B+D), C7/SS7, CCS (C6, C7), RBS (E&M, PLR, FXS-GS, FXO-GS, FXS-LS, FXO-LS)

DS3 voice quality enhancement VQE and echo cancellers 19 inch, 3U (44mm) chassis, 128ms. bidirectional echo canceller tail. DS3 Inputs and Outputs are balanced 75 Ohms BNC connectors.

Question: What is echo tail-displacement (echo tail off-set)?

Answer: Echo tail-displacement (echo tail off-set) is an important feature used in bidirectional echo cancellation, to make it effective and useful for bidirectional echo cancellation.

Explanation: Bidirectional (defined as near-end and far-end automatic echo cancellation operation) echo cancellers have the capability of cancelling echoes in both directions (on the Transmit as well as the Receive paths), by installing them at a single location. Bidirectional echo cancellers can be installed at a single location, either the near-end or the far-end, and used to cancel both near-end and far-end echo-tails, from a single installation.

Usually, satellite links and intercontinental VoIP circuits have fixed network delays which exceed the capabilities of commonly available (192 ms.) echo cancellers for bidirectional echo cancellation, thus making them unsuitable for bidirectional echo cancellation.

Example : An intercontinental satellite or a VoIP link may have a fixed end-to-end round-trip delay of 300ms., thereby rendering all commonly available echo cancellers, with even 192 ms. echo cancellation capabilities, ineffective for bidirectional echo cancellation.

Using the echo tail-displacement (echo tail off-set) feature, the user may offset and account for the fixed round-trip network delay on the return path so that the echo cancellation window on the return-path is shifted by 300ms., so as to allow the bidirectional echo canceller to function effectively in both directions and to cancel BOTH near-end, as well as the far-end echo-tails on the return path, even if the echo canceller is installed at the Near-end in a given network.

Echo tail-displacement (echo tail off-set) allows the user to program a delay off-set on the return path, so that the user may cancel both near-end and far-end echo-tail with a single echo canceller installation. The echo tail-displacement allows the user to compensate for the fixed network delays on the return path of the echo-tail, so that the user can effectively cancel, both near-end and far-end echoes using a single echo canceller without being limited by the fixed end-to-end delay of that network link.

Orion's echo canceller has a user programmable "echo tail-end displacement" (echo tail off-set) from 0 ms. to 512 ms.

This feature allows the use of a single echo canceller installation to cancel echo-tails in both directions over intercontinental satellite or VoIP links where the fixed network delays are excessive (beyond and in excess of (example) 192 ms. echo cancellation capability of the commonly sold bidirectional echo canceller solutions).

Question: My network has a total of 300ms. end-to-end delay. How can I use a 128ms. bidirectional echo canceller to cancel, both, near-end and far-end echoes?

Answer: The use of the "programmable echo tail-displacement" (echo tail off-set) feature in our echo cancellers allow the user to cancel echoes on the return path even if the network delays exceed 128 ms.

The fixed network delay shall be calculated ascertained and programmed as the "echo tail-displacement" on the return path. This shall allow the user to use a single echo canceller to cancel echoes, bidirectionally, even if the total network end-to end delay is in excess of 300 ms.

The Orion 128 ms. bidirectional echo canceller solution, equipped with a user programmable "echo tail-displacement" feature is superior than a simple single 192 ms. bidirectional echo canceller solution for cancelling both near-end and far-end echoes, even if the fixed round-trip network delays exceed 300 ms. (*please see the example above*).

Applications for the VCL-EC

Applications

- Wireless: GSM, CDMA, TDMA and Cellular Base Stations
- Digital Circuit Multiplication Equipment (DCME) : Satellite Communications and Multiplexers
- PCS, mobile and digital cordless wireless systems
- PBX and central office systems
- Datacomm: Voice over Frame Relay, Voice over ATM, and Voice over Internet
- Voice over ATM, Frame Relay or packet switching systems and fax transmissions
- Central Office and PBX: Network Trunks, Echo Canceller Pool, Common Equipment and Audio Conferencing Bridges
- Voice over datacomm including voice over Internet (VoIP), voice over ATM (VoATM) and Voice over Frame Relay (VoFR)

Datacomm Applications

- Voice Over Frame Relay
- Voice Over ATM
- Voice Over Internet / LAN

Satellite Communications Applications

- Digital Circuit Multiplication Equipment

Wireless Applications

- GSM, CDMA
- Digital Cordless and Cellular Base Stations

Central Office and PBX Applications

- Network Trunks
- Echo Canceller Pool
- Common Equipment
- Audio Conferencing Bridges

Voice Over ATM Applications

- A multi-channel echo canceller resource or pool is shared among many channels to reduce cost
- Echo cancellation is done at a DS0 level

Voice Over Frame Relay, ATM Applications

- Frame Relay and ATM routers and switches introduce large, variable and unpredictable delays.
- Echoes from the Public Switched Telephone Network (PSTN) in combination with the delays from Frame Relay and ATM equipment yield objectionable speech quality.

DS3 VQE & Echo Canceller per chassis - Features

Features	Highlights
<ul style="list-style-type: none"> ● USER PROGRAMMABLE ECHO TAIL DISPLACEMENT (Echo Tail Off-set): User definable echo-tail displacement is selectable between 0 ms. to 512 ms. on the return-path. This feature allows the user to cancel echo tails in BOTH directions (both near-end and far-end echo tails), even in most demanding conditions that are common on VoIP networks and satellite links. ● User Programmable Signaling Option The DS3 VQE and Echo Canceller supports: <ul style="list-style-type: none"> ▪ 672 Voice Channels with out-of-band signaling ▪ C7/SS7 signaling on any user selected time-slot ▪ 23B+D, PRI ISDN (23 Voice Channels +D Signaling Channel) ▪ Robbed Bit Signaling ▪ CCS (C6, C7) ▪ RBS (E&M, PLR, FXS-GS, FXO-GS, FXS-LS, FXO-LS) ▪ All signaling options are User Selectable/ User Programmable ▪ Allows digital data transmission on user-selected time-slots ● The DS3 echo canceller supports 2100 Hz fax/ analog data modem tone detection and echo canceller disabling on all channels. ● USER PROGRAMMABLE DEDICATED DATA CHANNELS: The user may specify/define the dedicated data channels so that they are always and completely by-passed from the echo cancellation circuitry - leaving those specifically assigned dedicated time-slots for digital data transmission (including video transmission). ● Option for user to select voice echo cancellation or digital-data transmission selectively on each time-slot for selective echo cancellation. This feature allows the user to use selected time-slots for data transmission to enable digital data /CCS signaling transmission. 	<ul style="list-style-type: none"> ● Transmission (data mode), while keeping the echo cancellation "ON" on the remaining time-slots (voice mode), on which echo is required to be cancelled. ● Provides voice echo cancellation of up to 128 ms. bidirectional (near-end and far-end echo canceller) for Ds3. ● Meets ITU-T G.168 (2000/2002) requirements for echo cancellation. ● Meets ITU-T G.169 specifications for VQE. ● Easy to use text based CLI commands for management and configuration. ● Orion offers the most compact DS3 Echo Cancellers and Voice Quality Enhancement (VQE) solution for the industry. ● Voice Quality Enhancement : <ul style="list-style-type: none"> ▪ ANR: Automatic Noise Reduction. Removes background noise. ▪ ALC: Automatic Level Control (maintains uniform VF levels). ▪ ALE: Automatic Level Enhancement (maintains uniform VF levels). ▪ Hybrid Echo Cancellation. ▪ Acoustic Echo Cancellation. ● Removes undesirable background noise and allows the natural background audio from the PSTN to pass through unaltered to the mobile subscriber, making the call sound clearer. ● Automatic Level Control dynamically adjusts speech levels up or down to the level optimal for the network, improving speech clarity and intelligibility. ● Acoustic Echo Control eliminates acoustic echo generating from digital mobile handsets and hands-free kits, enabling full-duplex speech. ● Noise Reduction reduces the background noise on mobile calls, enhancing overall voice quality. ● 2, DS-3 Interfaces. This saves material costs, configuration and set-up time and on going maintenance. Eliminates the need to have multiple T1 interfaces or T1 to DS3 multiplexers. Easy to install and easy to manage.

DS3 VQE & Echo Canceller per chassis - Features

Features	Highlights
<ul style="list-style-type: none"> • Bidirectional echo cancellers have the capability of canceling 128ms. echo-tails in both directions (on the Transmit as well as the Receive paths), by installing them at a single location. Our equipment's unique user programmable echo-tail off-set feature allows bi-directional echo cancellation from a single installation, in networks which may have end-to-end delays of even up to 512ms. These are usually found on satellite links and high latency VoIP networks, rendering the other echo cancellers, without this feature, in-effective. • Tone disabling per ITU-T, G.164 and G.165. • Echo-tail displacement allows user to program a delay off-set on return path and user can cancel near-end and far-end echo from single installation. • Signaling protocols supported: <ul style="list-style-type: none"> ▪ 672 Voice Channels with out-of-band signaling (C7/SS7 signaling on any user selected time-slot) ▪ 23B+D, PRI ISDN (23 Voice Channels +D signaling Channel) ▪ Robbed Bit signaling ▪ CCS (C6, C7) ▪ RBS (E&M, PLR, FXS-GS, FXO-GS, FXS-LS, FXO-LS) ▪ All signaling options are User Selectable/ User Programmable ▪ Allows digital data transmission on user-selected time-slots • Meets ITU-T G.164, G.165, G.168 (2000/2002) requirements for echo cancellation. • Meets ITU-T G.169 specifications for voice quality enhancement • Ensures excellent voice quality from the start of the call, during call transfer and cell hand-offs, and even after abrupt changes in network routing. 	<ul style="list-style-type: none"> • Delivers clear voice quality in the most challenging network environments. • Offers selection of voice quality enhancements features that include automatic level control and background noise reduction with acoustic echo control. • Ideally suited for mobile (GSM and CDMA) Networks to eliminate "background noise" to enable GSM Networks to function at Half-Rate (HR) thereby doubling spectrum usage in GSM networks <p>Remote Monitoring and Control</p> <ul style="list-style-type: none"> • CLI Command Interface • Local access through COM port (RS232 serial port) • Remote access through a 10BaseT Port over a TCP/IP network, telnet • The system is supplied with an easy-to-use Windows (95, 98, Me, XP) Graphical User Interface that provides the USER a complete control • Ensures echo canceller maintains excellent performance at all times in presence of tones or signals including DTMF tones • Improves voice quality performance on circuits with poor echo return loss (ERL) and unbalanced send and receive levels, resulting in improvement in service quality • Allows the use of a single Echo Canceller installation to cancel echo-tails in both directions • Stable performance across all hybrid and acoustic conditions • Low per-channel power consumption reduces cooling and power costs • Compact size reduces footprint requirements.

Application Diagrams

VCL-EC-DS3, VQE and DS3 Echo Cancellor

To cancel the echoes at both ends (near-end and far-end) of the Network with one 128 ms. bidirectional Echo Cancellor

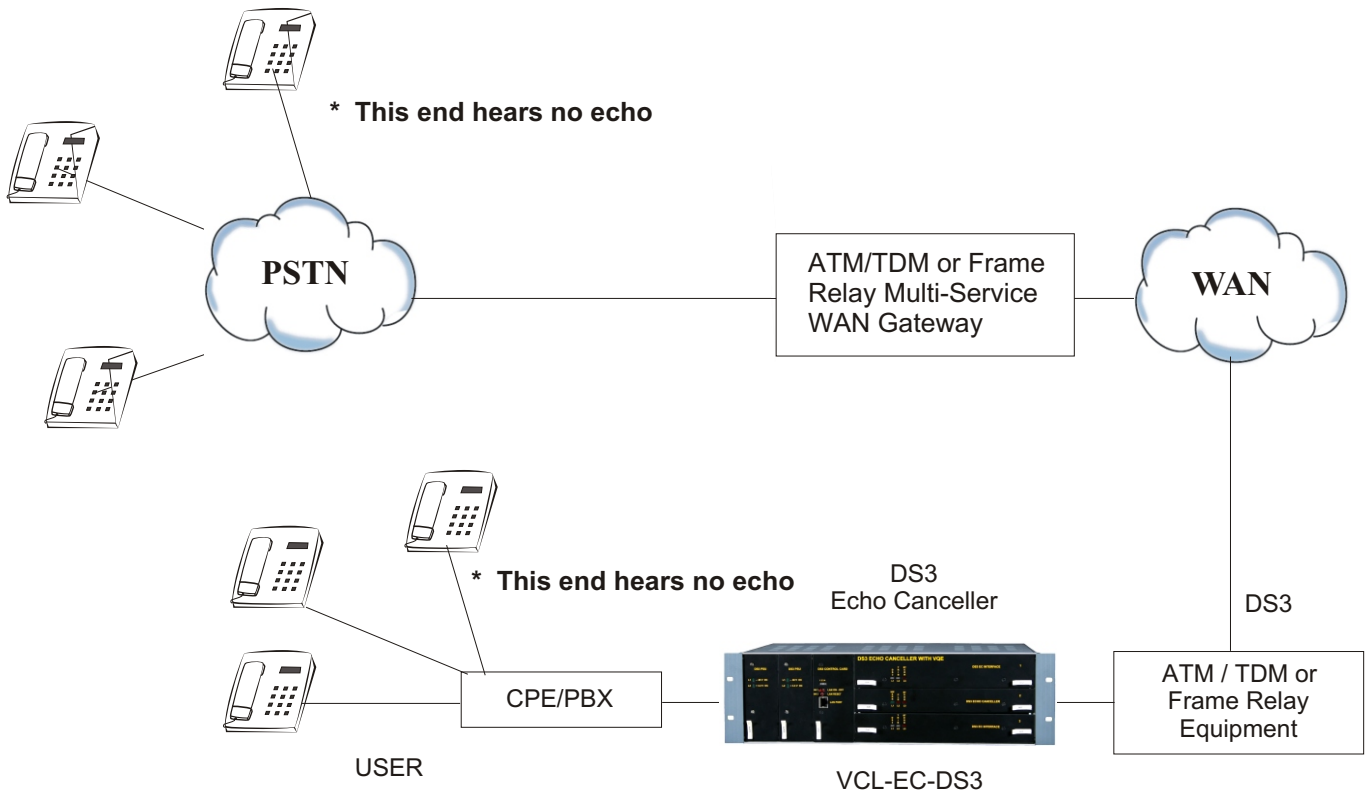

To cancel the echoes at both ends of the network with one 128 ms. bidirectional Echo Cancellor with user programmable Echo Tail Displacement (Echo Tail Off-set) Features

Note: The VCL-EC-DS3 Echo Cancellor offers User Programmable Echo Tail Displacement feature. User Definable Echo-Tail Displacement is selectable between 0 ms. to 512 ms. on the return-path. This feature allows the user to cancel echo-tails in both directions (both near-end and far-end echo tails), even in most demanding conditions that are common on VoIP networks and satellite links.

VCL-EC-DS3, VQE and DS3 Echo Cancellers
Shelf Description:

The VCL-EC-DS3 VQE is a 3U, 19-inch shelf, fitted with a backplane. The DS3 interface, power input, alarm extension, COM Port, LAN and external clock are all accessed from the system front panel and backpanel.

VCL-EC, DS3 Echo Cancellor
Front View of the Shelf

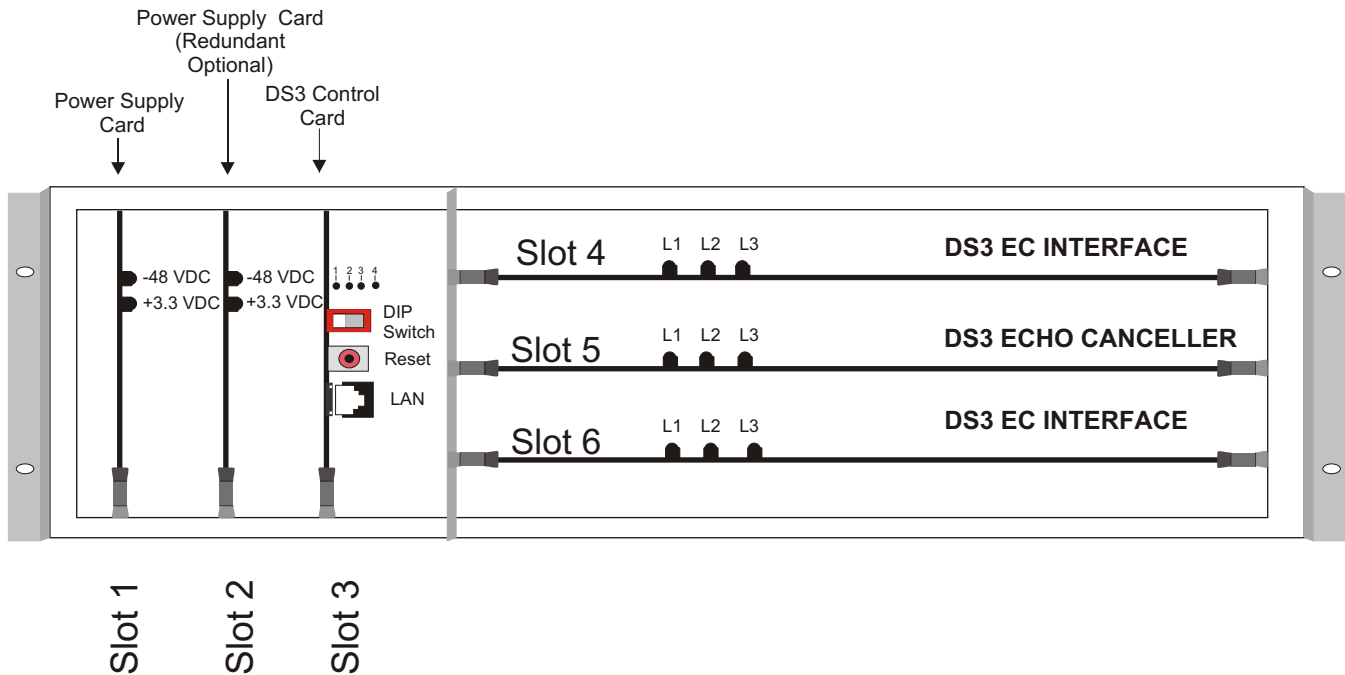

Front View (Left to Right)	Details	Part No.
Slot 1	PS, Power Supply Card	VCL-1495-PS
Slot 2	PS, Power Supply Card (Redundant Optional)	VCL-1495-PS
Slot 3	EC, DS3 Control Card	VCL-EC-DS3-NMS
Slot 4 to Slot 6	EC, DS3 Card	VCL-EC-DS3
19 Inch Shelf	3U, 19-inch shelf with connectorized Backplane	

Mechanical Specifications

Rack Mounting	Standard 19-Inch. DIN Rack
Height	133.00 mm.(3U)
Depth	260.00 mm.
Width	477.00 mm.
Weight	6.00 Kg. (1xDS3 VQE and Echo Cancellor per chassis)

Technical Specifications

DS3 (T3) Interface:

Number of DS3 Interfaces	2
Bit Rate	44.736 Mbps
Bit Rate Tolerance	+/- 20ppm
Line Code	B3ZS
Framing	* Meets ANSI T1.404 * M13 or C-bit parity
Pulse Shape	Meets ANSI T1.102-1993 and Bellcore GR-499-CORE
Connectors	BNC, Co-axial Un-balanced
Impedance	75 Ohms
Signal Level to Declare Loss of Signal Condition	≤ 20mV
Signal Level to Clear Loss of Signal Condition	≥ 90mV

Echo Cancellation

Echo Tail Cancellation	Up to 128ms. bidirectional (near end and far end)
Tone Disabler	As per ITU-T G.164, G.165
ERLE (Echo Return Loss Enhancement)	>35 dB (with 6dB ERL) at -10 dBm0 >65 dB with NLP enabled
ERL (Echo Return Loss)	Selectable Threshold Levels Options: 0, 3, 6 dB
Transmit / Receive Levels (Programmable)	Selectable Levels Options: -12, -9, -6, -3, 0, +3, +6, +9
Comfort Noise Insertion	User Selectable - Enable/Disable
Local Monitoring and Control	RS232 serial interface for Management through a PC COM Port
Remote Monitoring and Control	Ethernet (10BaseT) interface for remote LAN management and control
Local and Remote Provisioning	CLI (text commands) and GUI
Front Panel Indicators	- In SYNC/Failure - LEDs for power on/off, clock status
Environmental-Operational	0° C to 50° C
Humidity	5% to 95%, non-condensing
Voice Quality	Acoustic Echo Control (AEC) Adaptive Noise Reduction (ANR) Adaptive Listener Enhancement (ALE) Automatic Level Control (ALC) G.169
Signaling	Pass-Through Signaling Protocols supported: - 672 Voice Channels with out-of-band signaling - C7/SS7 signaling on any user selected time-slot - 23B+D, PRI ISDN (23 Voice Channels +D Signaling Channel) - Robbed Bit Signaling - CCS (C6, C7) - RBS (E&M, PLR, FXS-GS, FXO-GS, FXS-LS, FXO-LS) - All signaling options are User Selectable/User Programmable - Allows digital data transmission on user-selected time-slots

Clock Synchronisation

Internal	AT&T Tr62411, Telcordia GR-1244-CORE, Stratum 3, Stratum 4, Enhanced and Stratum 4, ETSI ETS 300 011, ITU-T G.813 Option 1
Loop-Timed External	100 Ohms -1.544 Mbits BITS Clock 75 Ohms -2 Mhz

Management Port Specifications 10BaseT LAN Management Port (with Telnet)

Network Interface	RJ-45 Ethernet 10BaseT or 100 BaseT-TX (auto sensing)
Compatibility	Ethernet Version 2.0 IEEE802.3
Protocols Supported	ARP, UDP/IP, TCP/IP, Telnet, ICMP, SNMP, DHCP, BOOTP, TFTP, Auto IP, SMTP and HTTP
LEDs	10Base-T & 100Base-TX Activity, Full/half duplex
Management	Serial login, Telnet login, GUI
EMI Compliance	<ul style="list-style-type: none"> - Radiated & conducted emissions - complies with Class B limits of EN55022:1998 - Direct & Indirect ESD - complies with EN55024:1998 - RF Electromagnetic Field Immunity - complies with EN55024:1998 - Electrical Fast Transient/Burst Immunity - complies with EN55024:1998 - Power Frequency Magnetic Field Immunity - complies with EN55024:1998 - RF Common Mode Conducted Susceptibility - complies with EN55024:1998

Ordering Information

Sr.	Product Description	Part #
1.	VCL-EC-DS3, VQE and DS3 Echo Cancellers, One DS3 128ms. bidirectional Echo Cancellor per Chassis	VCL-EC-DS3

